

MOTOPOMPE AUTOADESCANTI CON MOTORI DIESEL Stage V

SELF PRIMING MOTOR PUMPS WITH Stage V DIESEL ENGINES

MOTOPOMPES AUTOAMORÇANTES AVEC MOTEUR DIESEL Stage V

GMP
PUMPS



B4XR-A/ST (4"X4") KDW702

IMPIEGHI

Motopompa autoadescante realizzata in versione monoblocco a girante multipalare aperta a rasamento, adatta per il travaso di acque cariche, con girante e guarnizione meccanica speciali, piatto d'usura in acciaio inox e portello d'ispezione.

Una valvola a clapet posta all'interno del corpo pompa impedisce lo svuotamento della pompa dopo l'arresto.

Gruppo installato su base in acciaio con telaio porta serbatoio e carter protezione batteria (batteria fornita a richiesta)

USES

Self priming motor pump monobloc execution with multi-blades open impeller, suitable for pumping dirty water, with special impeller and special mechanical seal, inox wear disk and inspection door.

A suitable non return valve is placed inside the pump body to avoid the empty after stopping.

Group installed on a steel base with tank holder frame and battery protection cover (battery supplied on request)

APPLICATION

Motopompa autoamorçantes monobloc avec turbine ouverte plusieurs pales, indiquée pour le transvasement d'eau chargée, avec turbine et garniture mécanique spéciales, disque d'usure en acier inox et porte d'inspection.

Une valve à clapet est placée dans le corps de la pompe pour éviter le vidage après l'arrêt.

Groupe installé sur socle en acier avec cadre porte-réservoir et carter de protection batterie (batterie fournie sur demande)

CARATTERISTICHE

Altezza massima di aspirazione:	6 m
Max temperatura del liquido:	+70°C
Max passaggio corpi solidi:	32 mm
Portata massima:	127 m³/h
Prevalenza massima:	2,7 bar
Ø aspirazione e mandata:	4"G

FEATURES

Max. suction depth:	6 m
Max. liquid temperature:	+70°C
Max. solids diameter:	32 mm
Max. delivery:	127 m³/h
Max. manometric head:	2,7 bar
Ø inlet / outlet:	4"G

CARACTERISTIQUES

Hauteur d'aspiration maximale:	6 m
Température Max.:	+70°C
Max. diamètre des solides:	32 mm
Débit maximum:	127 m³/h
Hauteur manométrique:	2,7 bars
Ø aspiration & refoulement:	4"G

CARATTERISTICHE COSTRUTTIVE

Corpo pompa:	Ghisa (EN-GJL-200)
Corpo valvola:	Ghisa (EN-GJL-200)
Supporto motore:	Ghisa (EN-GJL-250)
Girante:	Ghisa (EN-GJL-200)
Disco usura:	Acciaio Inox (AISI 316)
Albero motore:	Acciaio Cromato
Tenuta mecc.:	Carb.Silicio/Nbr/Allumina

CONSTRUCTIVE CHARACTERISTICS

Pump body:	Cast iron (EN-GJL-200)
Valve body:	Cast iron (EN-GJL-200)
Support:	Cast iron (EN-GJL-250)
Impeller:	Cast iron (EN-GJL-200)
Wear disc:	Stainless Steel (AISI 316)
Motor shaft:	Stainless Steel
Seal:	Silicon Carbide/Nbr/Alumina

CARACTERISTIQUES DE CONSTRUCTION

Corps de pompe :	Fonte (EN-GJL-200)
Corps valve:	Fonte (EN-GJL-200)
Support:	Fonte (EN-GJL-250)
Turbine:	Fonte (EN-GJL-200)
Disque d'usure :	Acier Inox (AISI 316)
Arbre moteur:	Acier Chromé
Garniture:	Carbure de Silicium/Nbr/Alumine

VERSIONI SPECIALI E OPZIONI

Materiali di costruzione:
Ghisa (versione standard)
Bronzo marino
Acciaio Inox Aisi 316
Tenute meccaniche diverse

Accessori a richiesta:
Carrello biga con ruote e timone
Raccordi e tubi

SPECIAL VERSIONS

Constructive materials:
Cast Iron (standard version)
Marine Bronze
Cast stainless steel AISI 316
Different mechanical seals

Accessories on request:
Trolley biga with wheel and tow hooks
Fittings and pipes

VERSIONS SPECIALES

Matériaux constructifs:
Fonte (version standard)
Bronze marin
Acier inoxydable fondu AISI 316
Garnitures mécaniques différentes

Accessoires sur demande :
Cage biga a' roues et volan
Raccords et tuyaux

DATI MOTORE

MOTOR DATA

MOTEUR

Modello Model Modèle	Tipo Type Type	Cilindri Cylinders Cylindrées	Cilindrata Displacement Cylindrée	Potenza - NA Rating - NA Puissance- NA	Capacità serbatoio Tank capacity Contenance du réservoir	N° Giri Tours/min. R.P.M.	Avviamento Starter Démarrage
		[N°]	[cm³]	[kW] [CV]	[L]		
KDW702 E536	Motore diesel 4 tempi raffreddato a liquido 4-Stroke liquid cooled diesel engine Moteur diesel 4 temps, refroidi par liquide	2	686	10,7 14	15	3000	E

E: Avviamento Elettrico - Electric starting - Démarrage électrique

CURVE DI PRESTAZIONE

Tolleranze e curve secondo UNI EN ISO 9906 Appendice A. Le caratteristiche di funzionamento in questo catalogo si intendono con acqua pulita (peso specifico = 1000 kg/m³), e altezza monometrica di aspirazione di 1 m.c.a.

PERFORMANCES CURVES

Tolerances and curves according to UNI EN ISO 9906 Attachment A. The operating characteristics of the catalogue are to be understood with clear water (specific weight = 1000 kg/m³), a max manometric suction height of approximately 1 m.

COURBES DE PERFORMANCES

Tolérance et courbes conformes aux normes UNI EN ISO 9906 Annexe A. Les caractéristiques de fonctionnement du catalogue sont entendues pour fonctionnement avec eau propre (poids spécifique = 1000 kg/m³).

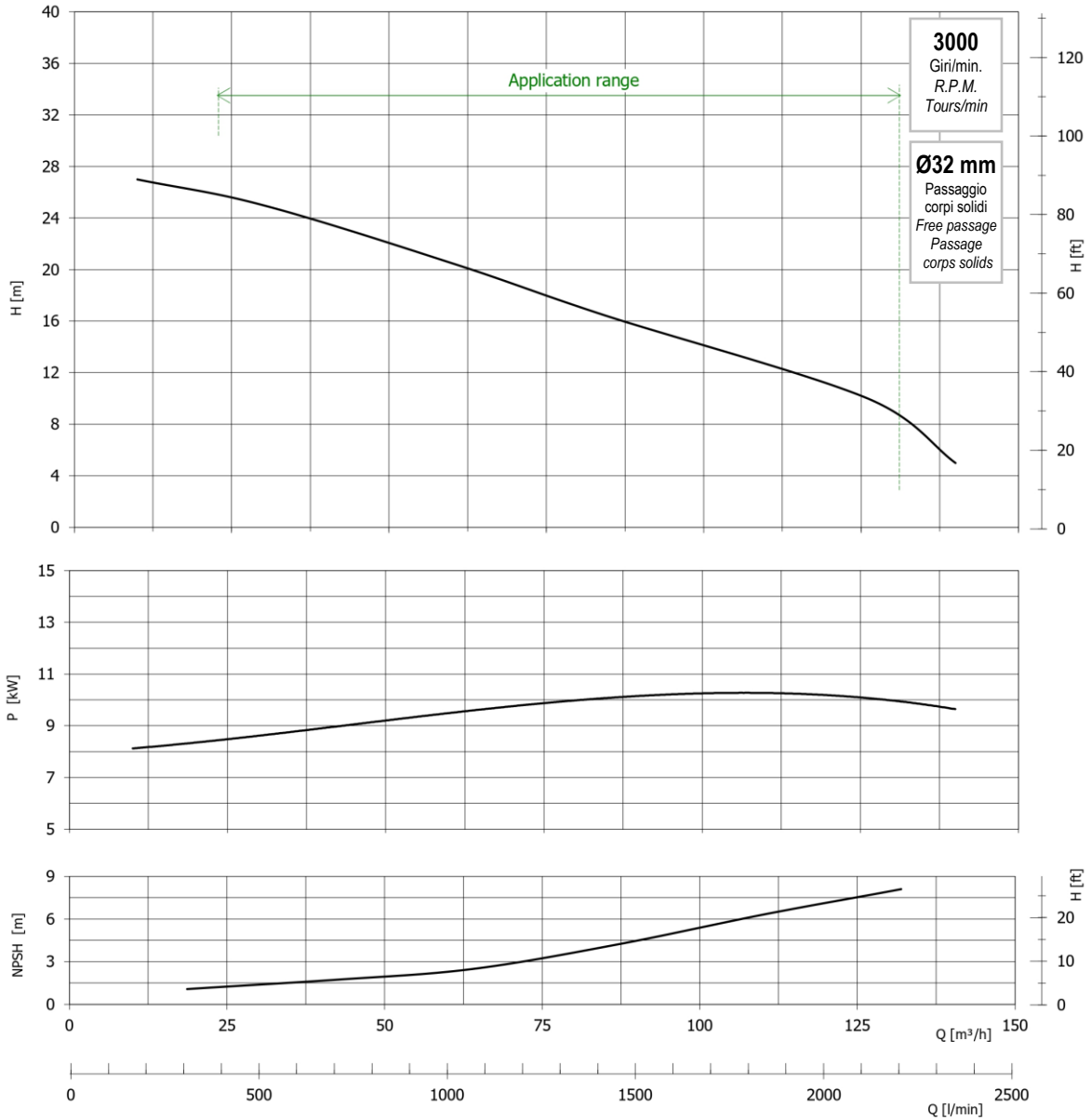

DIMENSIONI

DIMENSIONS

DIMENSIONS

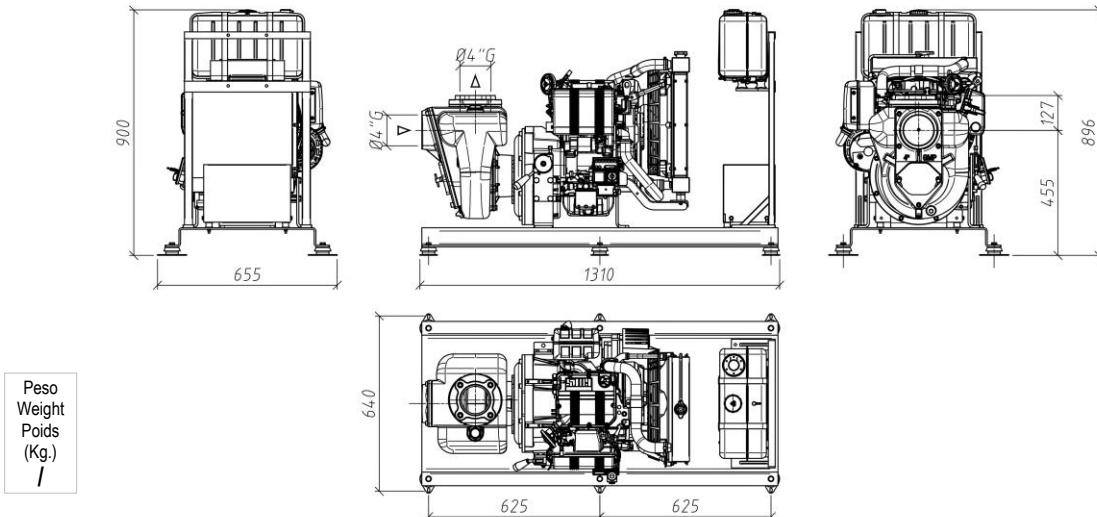

Peso
Weight
Poids
(Kg.)
/

MOTOPOMPE AUTOADESCANTI CON MOTORI DIESEL Stage V
SELF PRIMING MOTOR PUMPS WITH Stage V DIESEL ENGINES
MOTOPOMPES AUTOAMORÇANTES AVEC MOTEUR DIESEL Stage V

GMP
PUMPS

ACCESSORI

ACCESSORIES

ACCESSOIRES

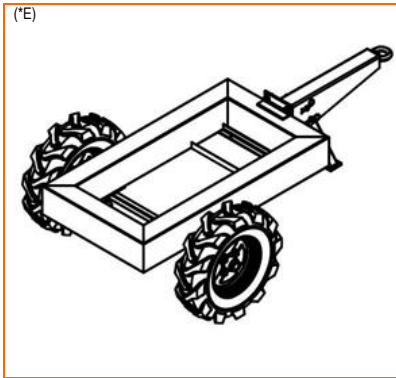

Carrello biga media con ruote e timone Cat.F574
 Trolley medium biga with wheel and tow hooks
 Cage moyenne biga a' roues et volan



Tubo aspirazione Ø100 in PVC Cat.9115
 Plasticized PVC hose – Tuyau en PVC plastifié



Tubo mandata Ø100 Cat.F554
 Flat plasticized PVC hose – Tuyau plat en PVC plastifié



Raccordo rapido diritto acciaio zincato 4"x100 Cat.1028
 Straight hose connection – Raccord rapide droit



Raccordi rapidi diritti acciaio zincato 4"x100 Cat.1038
 Straight hose connection – Raccord rapide droit



Succheruola acciaio zincato 4"x100 Cat.1052
 Suction strainer – Crépines sans clapet

(*) E: Avviamento Elettrico – Electric starting – Démarrage électrique

B4XR-A/ST (4"x4") KDW702