

MOTOPOMPE AUTOADESCANTI CON MOTORI DIESEL Stage V

SELF PRIMING MOTOR PUMPS WITH Stage V DIESEL ENGINES

MOTOPOMPES AUTOAMORÇANTES AVEC MOTEUR DIESEL Stage V

GMP
PUMPS



B3XR-A/X (3"X3") KDW702

IMPIEGHI

Motopompa autoadescante in acciaio inox realizzata in versione monoblocco a girante multipalare aperta a rasamento, particolarmente adatta per uso marino e circolazione di acqua di mare, o per travaso acque acide
Corpo, girante, e valvola in acciaio Inox.
Una valvola a clapet posta all'interno del corpo pompa impedisce lo svuotamento della pompa dopo l'arresto.
Gruppo installato su base in acciaio con telaio porta serbatoio e carter protezione batteria (batteria fornita a richiesta)

USES

Stainless steel self priming motor pump monobloc execution with multi-blades open impeller, suitable for pumping sea water and suitable for acid waters.
Pump casing, impeller, valve and sleeve are in Stainless steel.
A non return valve is placed inside the pump body to avoid the empty after stopping.
Group installed on a steel base with tank holder frame and battery protection cover (battery supplied on request)

APPLICATION

Motopompe autoamorçantes monobloc en acier inox avec turbine ouverte plusieurs pales, indiquée pour d'eau de mer, indiquées pour eaux acides.
Corps, turbine, valve et manchon sont en acier inox.
Une valve à clapet est placée dans le corps de la pompe pour éviter le vidage après l'arrêt.
Groupe installé sur socle en acier avec cadre porte-réservoir et carter de protection batterie (batterie fournie sur demande)

CARATTERISTICHE

Altezza massima di aspirazione: 6m
Max temperatura del liquido: +70°C
Max passaggio corpi solidi: 24 mm
Portata massima: 90 m³/h
Prevalenza massima: 3,5 bar
Ø aspirazione e mandata: 3" G

FEATURES

Max. suction depth: 6 m
Max. liquid temperature: +70°C
Max. solids diameter: 24 mm
Max. delivery: 90 m³/h
Max. manometric head: 3,5 bar
Ø inlet / outlet: 3" G

CARACTERISTIQUES

Hauteur d'aspiration maximale: 6 m
Température Max.: +70°C
Max. diamètre des solides: 24 mm
Débit maximum: 90 m³/h
Hauteur manométrique: 3,5 bars
Ø aspiration & refoulement: 3" G

CARATTERISTICHE COSTRUTTIVE

Corpo pompa: Acciaio Inox (AISI 316)
Corpo valvola: Acciaio Inox (AISI 316)
Supporto motore: Ghisa (EN-GJL-250)
Girante: Acciaio Inox (AISI 316)
Albero motore: Acciaio Inox (AISI 316)
Tenuta mecc.: Carbono/Nbr/Allumina/Aisi 316

CONSTRUCTIVE CHARACTERISTICS

Pump body: Stainless steel (AISI 316)
Valve body: Stainless steel (AISI 316)
Support: Cast iron (EN-GJL-250)
Impeller: Stainless steel (AISI 316)
Motor shaft: Stainless steel (AISI 316)
Seal: Carbon/Nbr/Alumina/Aisi 316

CARACTERISTIQUES DE CONSTRUCTION

Corps de pompe: Acier inox (AISI 316)
Corps valve: Acier inox (AISI 316)
Support: Fonte (EN-GJL-250)
Turbine: Acier inox (AISI 316)
Arbre moteur: Acier inox (AISI 316)
Garniture: Charbone/Nbr/Alumine/Aisi 316

VERSIONI SPECIALI E OPZIONI

Materiali di costruzione
Ghisa (standard version)
Ghisa (semi-trash version)
Bronzo marino
Tenute meccaniche diverse
Accessori a richiesta:
Carrello biga con ruote e timone
Tubi

SPECIAL VERSIONS

Materiali di costruzione
Cast iron (standard version)
Cast iron (semi-trash version)
Marine Bronze
Different mechanical seal
Accessories on request:
Trolley biga with wheel and tow hooks
Pipes

VERSIONS SPECIALES

Matériaux de construction
Fonte (standard version)
Fonte (semi-trash version)
Bronze Marine
Garnitures mécaniques différentes
Accessoires sur demande:
Cage biga a' roues et volan
Tuyaux

DATI MOTORE

MOTOR DATA

MOTEUR

Modello Model Modèle	Tipo Type Type	Cilindri Cylinders Cylindrées	Cilindrata Displacement Cylindrée	Potenza – NA Rating – NA Puissance- NA		Capacità serbatoio Tank capacity Contenance du réservoir	N° Giri Tours/min. R.P.M.	Avviamento Starter Démarrage
		[N°]	[cm³]	[kW]	[CV]	[L]		
KDW702 E536	Motore diesel 4 tempi raffreddato a liquido 4-Stroke liquid cooled diesel engine Moteur diesel 4 temps, refroidi par liquide	2	686	10,7	14	15	3000	E

E: Avviamento Elettrico – Electric starting – Démarrage électrique

CURVE DI PRESTAZIONE

Tolleranze e curve secondo UNI EN ISO 9906 Appendice A. Le caratteristiche di funzionamento in questo catalogo si intendono con acqua pulita (peso specifico = 1000 kg/m³), e altezza monometrica di aspirazione di 1 m.c.a.

PERFORMANCES CURVES

Tolerances and curves according to UNI EN ISO 9906 Attachment A. The operating characteristics of the catalogue are to be understood with clear water (specific weight = 1000 kg/m³), a max manometric suction height of approximately 1 m.

COURBES DE PERFORMANCES

Tolérance et courbes conformes aux normes UNI EN ISO 9906 Annexe A. Les caractéristiques de fonctionnement du catalogue sont entendues pour fonctionnement avec eau propre (poids spécifique = 1000 kg/m³).

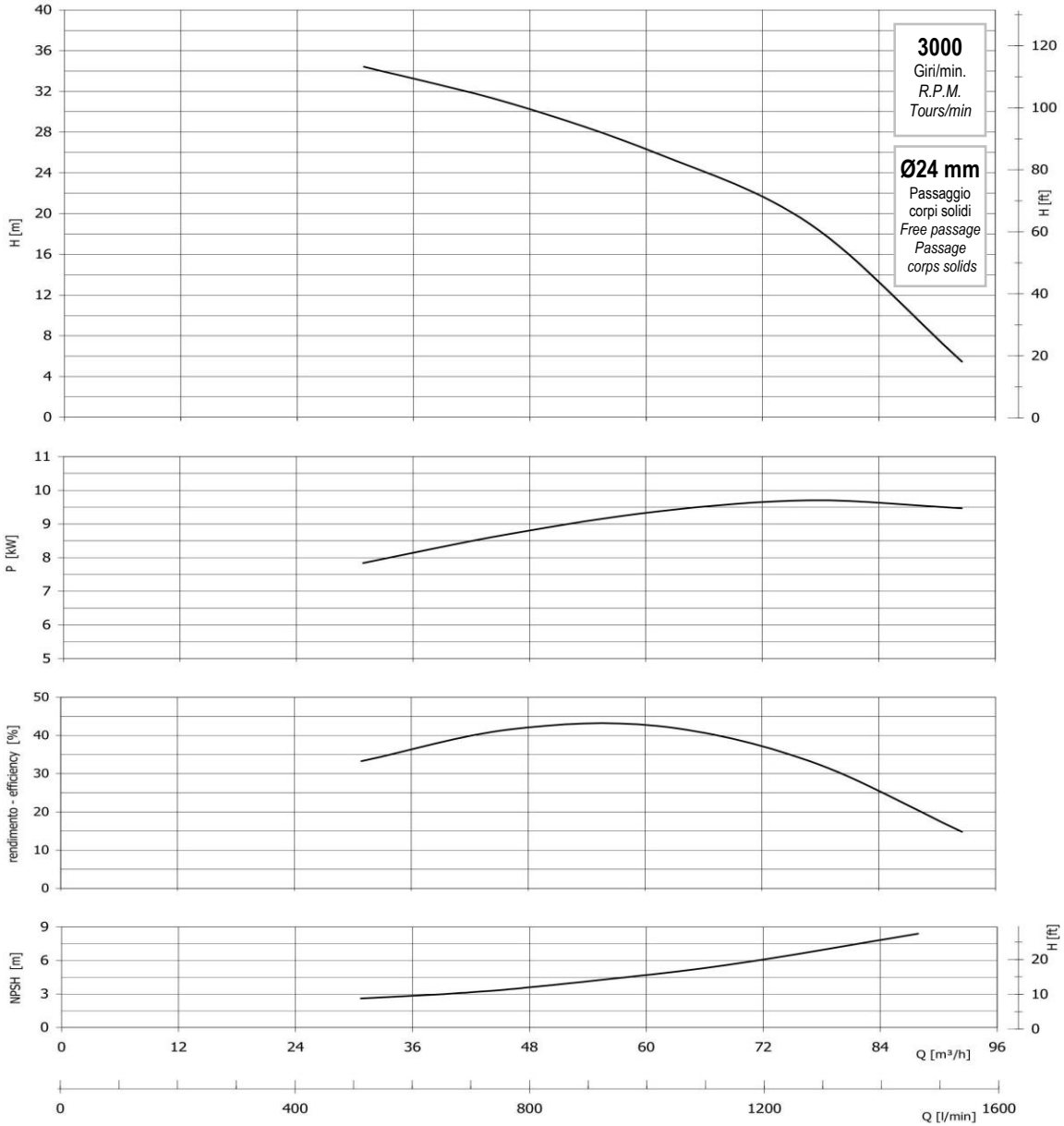

DIMENSIONI

DIMENSIONS

DIMENSIONS

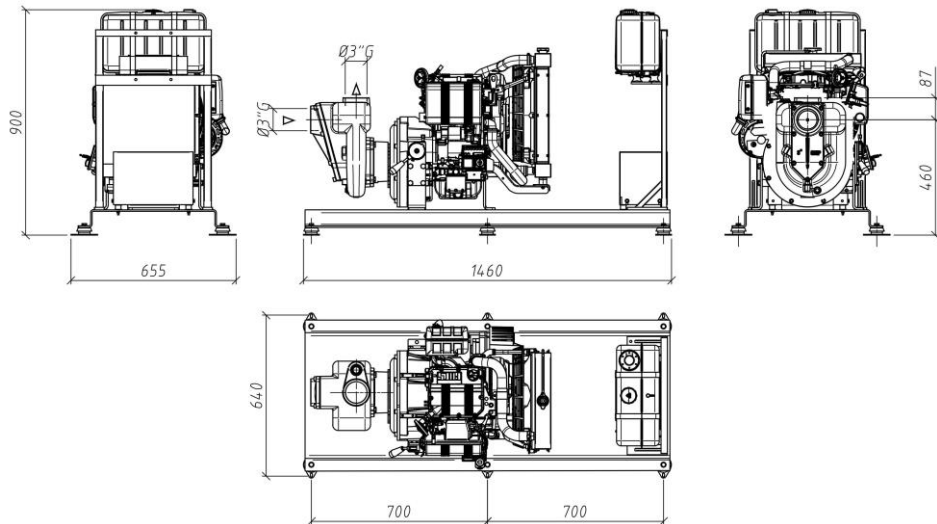

Peso
Weight
Poids
(Kg.)
/

MOTOPOMPE AUTOADESCANTI CON MOTORI DIESEL Stage V
SELF PRIMING MOTOR PUMPS WITH Stage V DIESEL ENGINES
MOTOPOMPES AUTOAMORÇANTES AVEC MOTEUR DIESEL Stage V

GMP
PUMPS

B3XR-A/X (3"X3") KDW702

ACCESSORI

ACCESSORIES

ACCESSOIRES

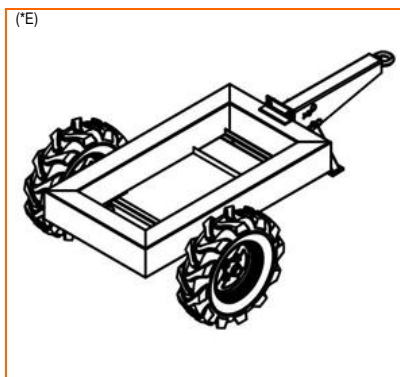

Carrello biga media con ruote e timone Cat.F574
Trolley medium biga with wheel and tow hooks
Cage moyenne biga a' roues et volan



Tubo aspirazione Ø80 in PVC Cat.9114
Plasticized PVC hose – Tuyau en PVC plastifié



Tubo mandata Ø80 Cat.9107
Flat plasticized PVC hose – Tuyau plat en PVC plastifié

(*) E: Avviamento Elettrico – Electric starting – Démarrage électrique