

MOTOPOMPE CENTRIFUGHE CON MOTORI DIESEL

CENTRIFUGAL MOTOR PUMPS WITH DIESEL ENGINES

MOTOPOMPES CENTRIFUGES AVEC MOTEUR DIESEL

GMP
PUMPS

BZZPM (2 1/2" X 2") KD625/2

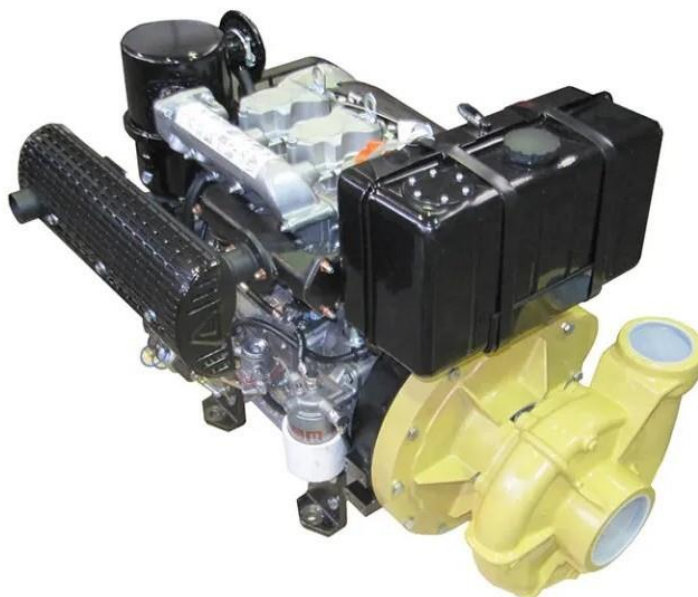

IMPIEGHI

Motopompa centrifuga in ghisa realizzata in versione monoblocco con girante chiusa, per travaso di acque pulite, non abrasive. Particolarmente indicata per piccole irrigazioni e per circuiti di raffreddamento/refrigerazione nel campo industriale.

USES

Cast iron centrifugal motor pump monobloc execution with closed impeller, suitable for pumping clean absolutely not abrasive. Particularly suitable for small irrigation and for cooling/refrigeration circuits in the industrial field.

APPLICATION

Motopompe en fonte centrifuges réalisée en version monobloc avec roue fermée, pour le transfert d'eau claire, non abrasive. Particulièrement adapté aux petites irrigations et aux circuits de refroidissement/réfrigération dans le champ industriel.

CARATTERISTICHE

Altezza massima di aspirazione: 6 m
Max temperatura del liquido: +70°C
Max passaggio corpi solidi: /
Portata massima: 49 m³/h
Prevalenza massima: 7,1 bar
Ø aspirazione: 2 1/2" G
Ø mandata: 2" G

FEATURES

Max. suction depth: 6 m
Max. liquid temperature: +70°C
Max. solids diameter: /
Max. delivery: 49 m³/h
Max. manometric head: 7,1 bar
Ø inlet: 2 1/2" G
Ø outlet: 2" G

CARACTERISTIQUES

Hauteur d'aspiration maximale: 6 m
Température Max.: +70°C
Max. diamètre des solides: /
Débit maximum: 49 m³/h
Hauteur manométrique: 7,1 bars
Ø aspiration: 2 1/2" G
Ø refoulement: 2" G

CARATTERISTICHE COSTRUTTIVE

Corpo pompa: Ghisa (EN-GJL-200)
Supporto motore: Ghisa (EN-GJL-250)
Girante: Ghisa (EN-GJL-200)
Albero motore: Acciaio Cromato
Tenuta meccanica: Carbone/Nbr/Allumina

CONSTRUCTIVE CHARACTERISTICS

Pump body: Cast iron (EN-GJL-200)
Support: Cast iron (EN-GJL-250)
Impeller: Cast iron (EN-GJL-200)
Motor shaft: Chromed Steel
Mechanical Seal: Carbon/Nbr/Alumina

CARACTERISTIQUES DE CONSTRUCTION

Corps de pompe : Fonte (EN-GJL-200)
Support: Fonte (EN-GJL-250)
Turbine: Fonte (EN-GJL-200)
Arbre moteur: Acier chromé
Garniture: Charbone/Nbr/Alumine

VERSIONI SPECIALI E OPZIONI

Accessori a richiesta:
Base in acciaio
Carrello biga con ruote e timone

SPECIAL VERSIONS

Accessories on request:
Steel base
Trolley biga with wheel and tow hooks

VERSIONS SPECIALES

Accessoires sur demande :
Base en acier
Cage biga a' roues et volan

DATI MOTORE

MOTOR DATA

MOTEUR

Modello Model Modèle	Tipo Type Type	Cilindri Cylinders Cylindrées [N°]	Cilindrata Displacement Cylindrée [cm³]	Potenza – NA Rating – NA Puissance- NA [kW] [CV]	Capacità serb. Tank capacity Contenance du réservoir [L]	N° Giri Tours/min. R.P.M.	Avviamento Starter Démarrage
KD-625/2	Motore diesel 4 tempi raffreddato ad aria 4-Stroke air cooled diesel engine Moteur diesel 4 temps, refroidi par air	2	1248	17 23,2	10	3000	E

R : Avviamento a strappo con autoavvolgente – Recoil starting – Démarrage lanceur

E: Avviamento Elettrico – Electric starting – Démarrage électrique

MOTOPOMPE CENTRIFUGHE CON MOTORI DIESEL

CENTRIFUGAL MOTOR PUMPS WITH DIESEL ENGINES

MOTOPOMPES CENTRIFUGES AVEC MOTEUR DIESEL

B2ZPM (2 1/2" X 2") KD625/2

CURVE DI PRESTAZIONE

Tolleranze e curve secondo UNI EN ISO 9906 Appendice A
Le caratteristiche di funzionamento in questo catalogo si intendono con acqua pulita (peso specifico = 1000 kg/m³).

PERFORMANCES CURVES

Tolerances and curves according to UNI EN ISO 9906 Attachment A
The operating characteristics of the catalogue are to be understood with clear water (specific weight = 1000 kg/m³).

COURBES DE PERFORMANCES

Tolérance et courbes conformes aux normes UNI EN ISO 9906 Annexe A.
Les caractéristiques de fonctionnement du catalogue sont entendues pour fonctionnement avec eau propre (poids spécifique = 1000 kg/m³).

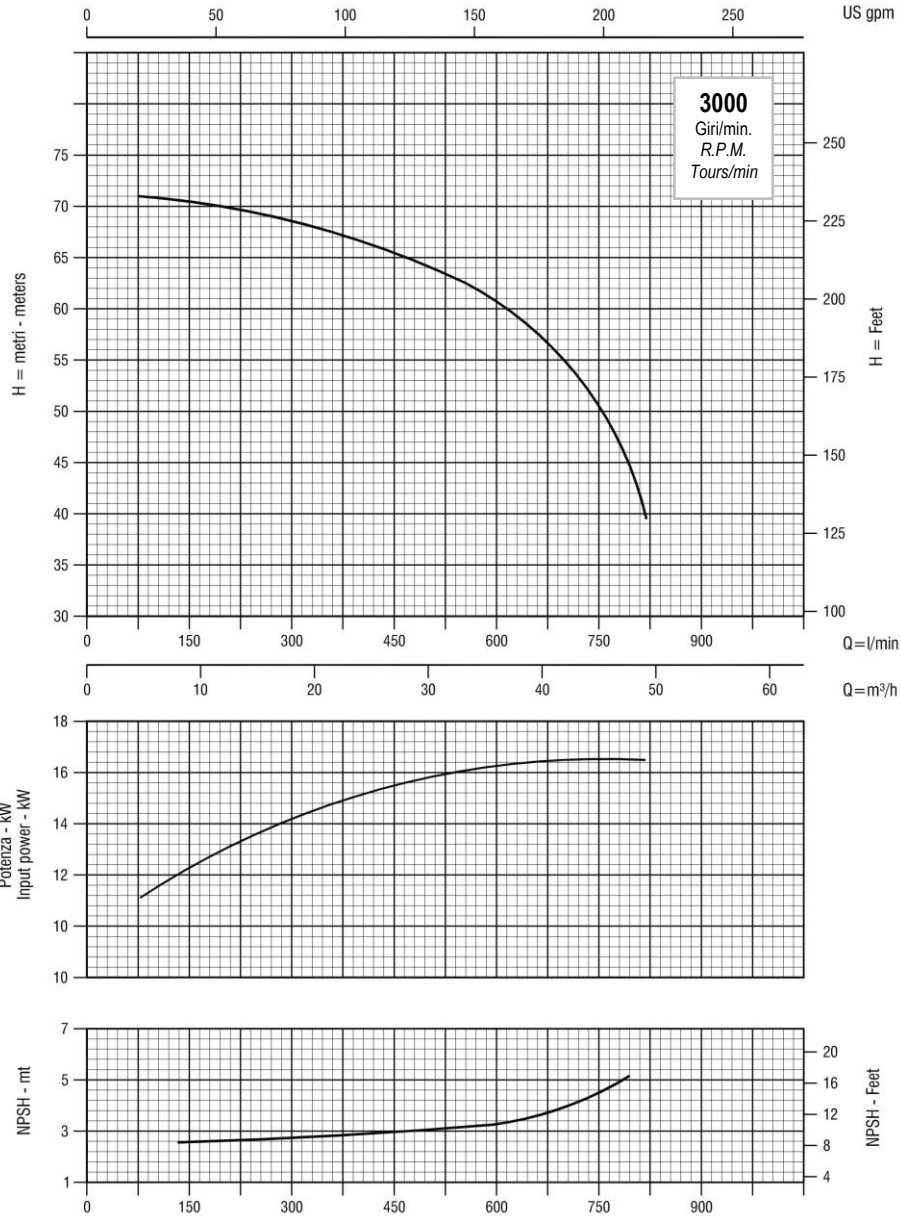

DIMENSIONI

DIMENSIONS

DIMENSIONS

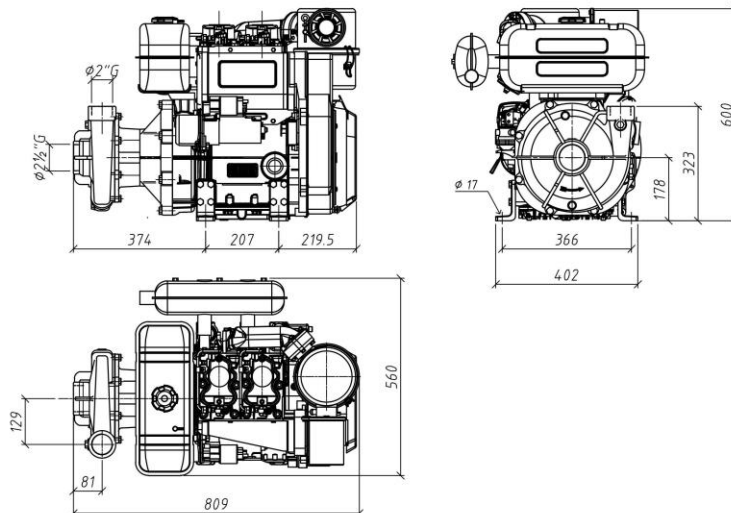

Peso
Weight
Poids
(Kg.)
143

MOTOPOMPE CENTRIFUGHE CON MOTORI DIESEL
CENTRIFUGAL MOTOR PUMPS WITH DIESEL ENGINES
MOTOPOMPES CENTRIFUGES AVEC MOTEUR DIESEL

GMP
PUMPS

ACCESSORI

ACCESSORIES

ACCESSOIRES

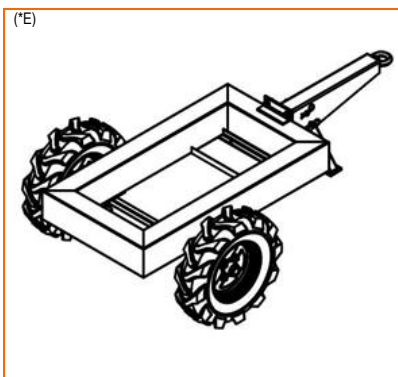

Carrello biga piccola con ruote e timone Cat.1709
Trolley small biga with wheel and tow hooks
Cage petite biga a' roues et volan

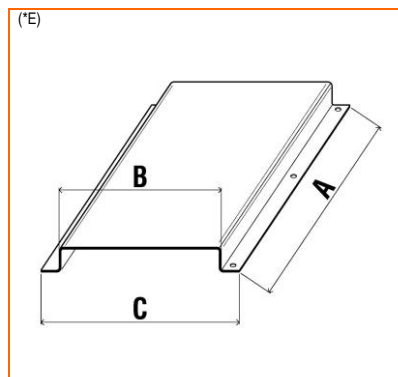

Base fissa 1240x450x550
Fixed Base – Base Fixe

(*)E: Avviamento Elettrico – *Electric starting* – *Démarrage électrique*

BZZPM (2 1/2" X 2") KD625/2