

MOTOPOMPE AUTOADESCANTI CON MOTORI BENZINA "HONDA" SELF PRIMING MOTOR PUMPS WITH "HONDA" GASOLINE ENGINES MOTOPOMPES AUTOAMORÇANTES AVEC MOTEUR A' ESSENCE "HONDA"

GMP
PUMPS

B3XR-A (3"X3") GX 390

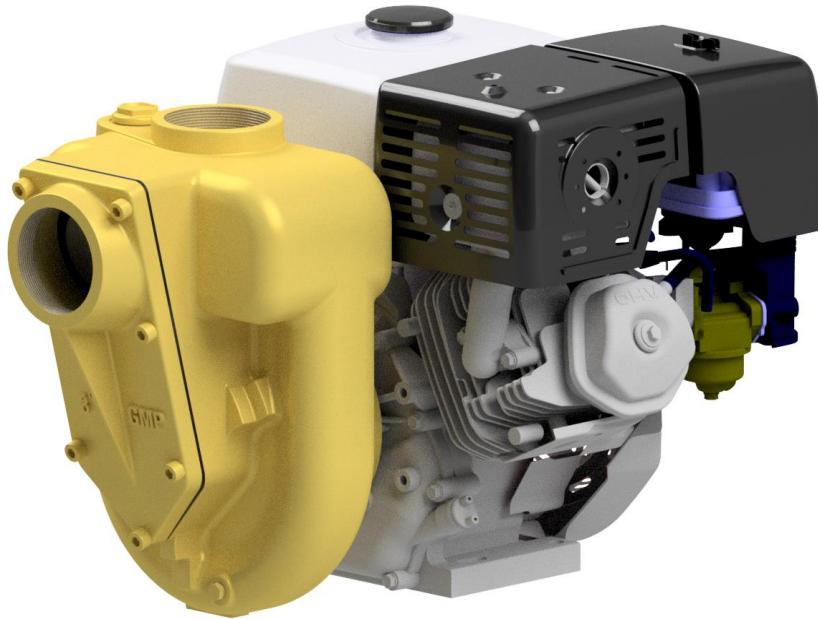

IMPIEGHI

Motopompa autoadescante realizzata in versione monoblocco a girante multipalare aperta adatta per travaso di acque chiare o leggermente sporche, assolutamente non abrasive. Una valvola a clapet posta all'interno del corpo pompa impedisce lo svuotamento della pompa dopo l'arresto.

USES

Self priming motor pump monobloc execution with multi-blades open impeller, suitable for pumping clean or slightly dirty waters, absolutely not abrasive. A suitable non return valve is placed inside the pump body to avoid the empty of the pump after stopping.

APPLICATION

Motopompe autoamorçantes monobloc avec turbine ouverte plusieurs pales, indiquée pour le transvasement d'eau claire ou légèrement chargées, mai absolument pas abrasive. Une valve à clapet est placée dans le corps de la pompe pour éviter le vidage après l'arrêt.

CARATTERISTICHE

Altezza massima di aspirazione: 6m
 Max temperatura del liquido: +70°C
 Max passaggio corpi solidi: 19 mm
 Portata massima: 76 m³/h
 Prevalenza massima: 3,9 bar
 Ø aspirazione e mandata: 3" G

FEATURES

Max. suction depth: 6 m
 Max. liquid temperature: +70°C
 Max. solids diameter: 19 mm
 Max. delivery: 76 m³/h
 Max. manometric head: 3,9 bar
 Ø inlet / outlet: 3" G

CARACTERISTIQUES

Hauteur d'aspiration maximale: 6 m
 Température Max.: +70°C
 Max. diamètre des solides: 19 mm
 Débit maximum: 76 m³/h
 Hauteur manométrique: 3,9 bars
 Ø aspiration & refoulement: 3" G

CARATTERISTICHE COSTRUTTIVE

Corpo pompa: Ghisa (EN-GJL-200)
 Corpo valvola: Ghisa (EN-GJL-200)
 Supporto motore: Ghisa (EN-GJL-250)
 Girante: Ghisa (EN-GJL-200)
 Albero motore: Acciaio Cromato
 Tenuta meccanica: Carbone/Allumina/Nbr (BVP2FF1)

CONSTRUCTIVE CHARACTERISTICS

Pump body: Cast iron (EN-GJL-200)
 Valve body: Cast iron (EN-GJL-200)
 Support: Cast iron (EN-GJL-250)
 Impeller: Cast iron (EN-GJL-200)
 Motor shaft: Chromed Steel
 Seal: Carbon/Alumina/Nbr (BVP2FF1)

CARACTERISTIQUES DE CONSTRUCTION

Corps de pompe : Fonte (EN-GJL-200)
 Corps valve: Fonte (EN-GJL-200)
 Support: Fonte (EN-GJL-250)
 Turbine: Fonte (EN-GJL-200)
 Arbre moteur: Acier chromé
 Garniture: Charbon/Albumine/Nbr (BVP2FF1)

VERSIONI SPECIALI E OPZIONI

Materiali di costruzione:
 Bronzo marino (ASTM B145 C 95800)
 Tenute meccaniche diverse
 Accessori a richiesta:
 Base con maniglie
 Gabbia
 Carrello
 Raccordi e tubi

SPECIAL VERSIONS

Constructive materials:
 Marine Bronze (ASTM B145 C95800)
 Different mechanical seals
 Accessories on request:
 Base with handles
 Cage
 Trolley
 Fittings and pipes

VERSIONS SPECIALES

Matériaux constructifs:
 Bronze marin (ASTM B145 C95800)
 Garnitures mécaniques différentes
 Accessoires sur demande :
 Base avec poignées
 Cage
 Brouette
 Raccords et tuyaux

DATI MOTORE

MOTOR DATA

MOTEUR

Modello Model Modèle	Tipo Type Type	Cilindri Cylinders Cylindrées	Cilindrata Displacement Cylindrée	Potenza – NA Rating – NA Puissance- NA		Capacità serb. Tank capacity Contenance du réservoir	N° Giri Tours/min. R.P.M.	Avviamento Starter Démarrage
		[N°]	[cm³]	[kW]	[CV]	[L]		
GX 390	Motore diesel 4 tempi raffreddato ad aria 4-Stroke air cooled diesel engine Moteur diesel 4 temps, refroidi par air	1	389	7	9,4	6,1	3600	R / E

R : Avviamento a strappo con autoavvolgente – Recoil starting – Démarrage lanceur

E: Avviamento Elettrico – Electric starting – Démarrage électrique

MOTOPOMPE AUTOADESCANTI CON MOTORI BENZINA "HONDA" SELF PRIMING MOTOR PUMPS WITH "HONDA" GASOLINE ENGINES MOTOPOMPES AUTOAMORÇANTES AVEC MOTEUR A' ESSENCE "HONDA"

B3XR-A (3"x3") GX 390

CURVE DI PRESTAZIONE

Tolleranze e curve secondo UNI EN ISO 9906 Appendice A
Le caratteristiche di funzionamento in questo catalogo si intendono con acqua pulita (peso specifico = 1000 kg/m³).

PERFORMANCES CURVES

Tolerances and curves according to UNI EN ISO 9906 Attachment A
The operating characteristics of the catalogue are to be understood with clear water (specific weight = 1000 kg/m³).

COURBES DE PERFORMANCES

Tolérance et courbes conformes aux normes UNI EN ISO 9906 Annexe A.
Les caractéristiques de fonctionnement du catalogue sont entendues pour fonctionnement avec eau propre (poids spécifique = 1000 kg/m³).

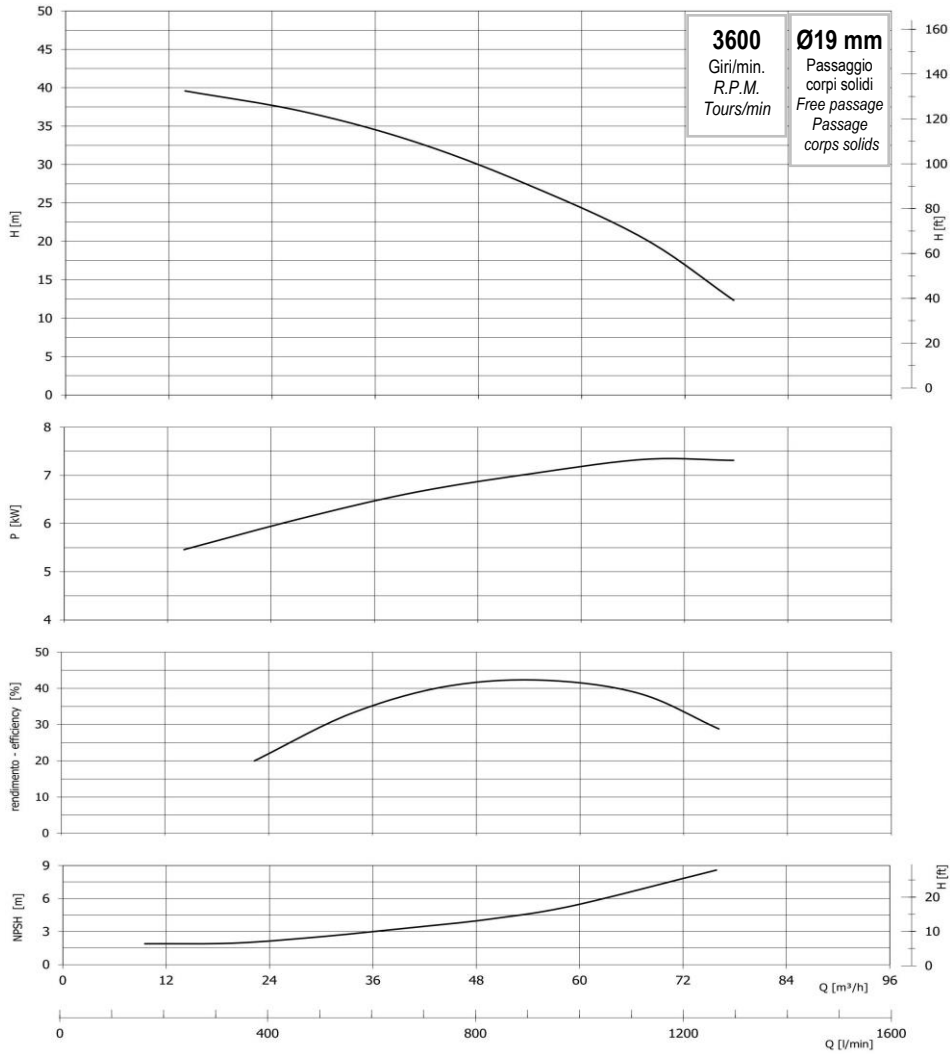

DIMENSIONI

DIMENSIONS

DIMENSIONS

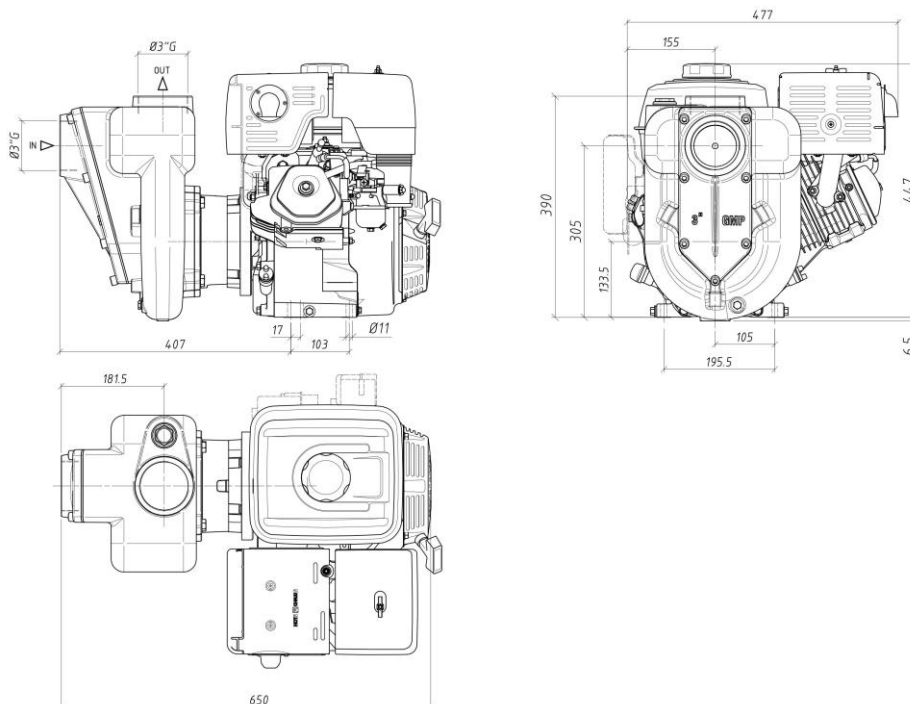

Peso
Weight
Poids
(Kg.)
67

MOTOPOMPE AUTOADESCANTI CON MOTORI BENZINA "HONDA"
SELF PRIMING MOTOR PUMPS WITH "HONDA" GASOLINE ENGINES
MOTOPOMPES AUTOAMORÇANTES AVEC MOTEUR A' ESSENCE "HONDA"



B3XR-A (3"X3") GX 390

ACCESSORI

ACCESSORIES

ACCESSOIRES

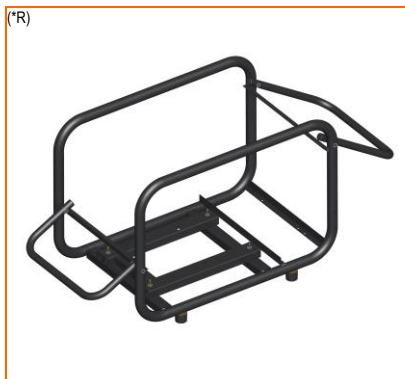

(*R)

Gabbia Media Cat.F934
 Medium cage – Cage Moyenne



(*E)

Carrello grande 2 ruote con manico Cat.F917
 2-wheels medium trolley with handle – Brouette grande



(*R)

Carrello Grande Cat.1708
 Big trolley – Brouette Grande



Tubo aspirazione Ø80 in PVC Cat.9114
 Plasticized PVC hose – Tuyau en PVC plastifié



Tubo mandata Ø80 Cat.9107
 Flat plasticized PVC hose – Tuyau plat en PVC plastifié



Raccordi rapidi dritti in Acciaio Zincato Cat.1027
 Straight hose connections – Raccords rapide droits



Raccordi rapidi curvi in Acciaio Zincato Cat.1037
 Curved hose connections – Raccords rapides corbe



Succheruole in Acciaio Zincato Cat.1051
 Suction strainers – Crépines sans clapet

(*) R : Avviamento a strappo con autoavvolgente – Recoil starting – Démarrage lanceur E: Avviamento Elettrico – Electric starting – Démarrage électrique