

MOTOPOMPE AUTOADESCANTI CON MOTORI BENZINA "HONDA" SELF PRIMING MOTOR PUMPS WITH "HONDA" GASOLINE ENGINES MOTOPOMPES AUTOAMORÇANTES AVEC MOTEUR A' ESSENCE "HONDA"

GMP
PUMPS

B2KQ-A/ST (2"X2") GX 160

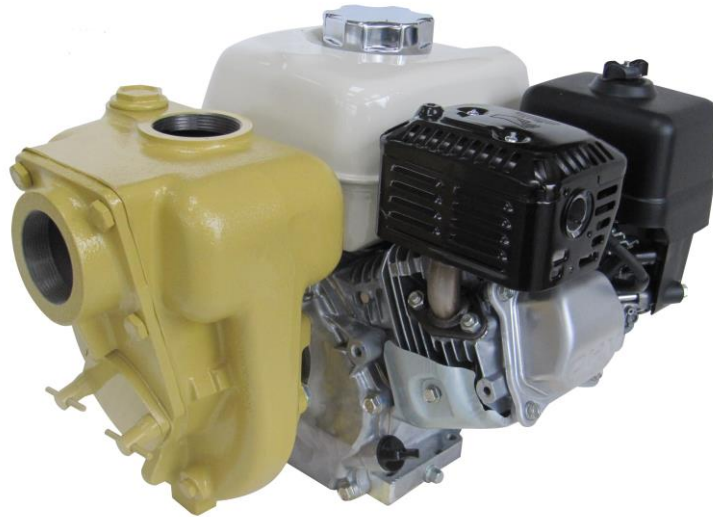

IMPIEGHI

Motopompa autoadescante realizzata in versione monoblocco a girante multipalare aperta adatta per travaso di acque cariche, con girante e guarnizione meccanica speciali, piatto d'usura in acciaio inox e portello ispezione.

Una valvola a clapet posta all'interno del corpo pompa impedisce lo svuotamento della pompa dopo l'arresto.

USES

Self priming motor pump monobloc execution with multi-blades open impeller, suitable for pumping clean dirty waters, with special impeller and special mechanical seal, inox wear disk and inspection door.

A suitable non return valve is placed inside the pump body to avoid the empty of the pump after stopping.

APPLICATION

Motopompe autoamorçantes monobloc avec turbine ouverte plusieurs pales, indiquée pour le transvasement d'eau chargées, avec turbine et garniture mécanique spéciales, disque d'usure en acier inox et porte d'inspection.

Une valve à clapet est placée dans le corps de la pompe pour éviter le vidage après l'arrêt.

CARATTERISTICHE

Altezza massima di aspirazione:	6m
Max temperatura del liquido:	+70°C
Max passaggio corpi solidi:	16 mm
Portata massima:	30 m³/h
Prevalenza massima:	2,7 bar
Ø aspirazione e mandata:	2" G

FEATURES

Max. suction depth:	6 m
Max. liquid temperature:	+70°C
Max. solids diameter:	16 mm
Max. delivery:	30 m³/h
Max. manometric head:	2,7 bar
Ø inlet / outlet:	2" G

CARACTERISTIQUES

Hauteur d'aspiration maximale:	6 m
Température Max.:	+70°C
Max. diamètre des solides:	16 mm
Débit maximum:	30 m³/h
Hauteur manométrique:	2,7 bars
Ø aspiration & refoulement:	2" G

CARATTERISTICHE COSTRUTTIVE

Corpo pompa:	Ghisa (EN-GJL-200)
Corpo valvola:	Ghisa (EN-GJL-200)
Supporto motore:	Ghisa (EN-GJL-250)
Disco d'usura:	Acciaio Inox Aisi 316
Girante:	Ghisa (EN-GJL-200)
Albero motore:	Acciaio Cromato
Tenuta meccanica:	Carburo Silicio/Nbr/Allumina

CONSTRUCTIVE CHARACTERISTICS

Pump body:	Cast iron (EN-GJL-200)
Valve body:	Cast iron (EN-GJL-200)
Support:	Cast iron (EN-GJL-250)
Wear disc:	Stainless Steel Aisi 316
Impeller:	Cast iron (EN-GJL-200)
Motor shaft:	Chromed Steel
Seal:	Silicon Carbide/Nbr/Alumina

CARACTERISTIQUES DE CONSTRUCTION

Corps de pompe:	Fonte (EN-GJL-200)
Corps valve:	Fonte (EN-GJL-200)
Support:	Fonte (EN-GJL-250)
Disque d'usure:	Acier Inox 316
Turbine:	Fonte (EN-GJL-200)
Arbre moteur:	Acier Chromé
Garniture:	Carbure de Silicium/Nbr/Alumine

VERSIONI SPECIALI E OPZIONI

Materiali di costruzione:
 Bronzo marino (ASTM B145 C 95800)
 Tenute meccaniche diverse

Accessori a richiesta:
 Base con maniglie
 Gabbia
 Carrello
 Raccordi e tubi

SPECIAL VERSIONS

Constructive materials:
 Marine Bronze (ASTM B145 C95800)
 Different mechanical seals

Accessories on request:
 Base with handles
 Cage
 Trolley
 Fittings and pipes

VERSIONS SPECIALES

Matériaux constructifs:
 Bronze marin (ASTM B145 C95800)
 Garnitures mécaniques différentes

Accessoires sur demande :
 Base avec poignées
 Cage
 Brouette
 Raccords et tuyaux

DATI MOTORE

MOTOR DATA

MOTEUR

Modello Model Modèle	Tipo Type Type	Cilindri Cylinders Cylindrées	Cilindrata Displacement Cylindrée	Potenza - NA Rating - NA Puissance- NA	Capacità serb. Tank capacity Contenance du réservoir	N° Giri Tours/min. R.P.M.	Avviamento Starter Démarrage
		[N°]	[cm³]	[kW] [CV]	[L]		
GX160	Motore diesel 4 tempi raffreddato ad aria 4-Stroke air cooled diesel engine Moteur diesel 4 temps, refroidi par air	1	163	2,9 4	3,1	3600	R / E

R : Avviamento a strappo con autoavvolgente - Recoil starting - Démarrage lanceur

E : Avviamento Elettrico - Electric starting - Démarrage électrique

MOTOPOMPE AUTOADESCANTI CON MOTORI BENZINA "HONDA" SELF PRIMING MOTOR PUMPS WITH "HONDA" GASOLINE ENGINES MOTOPOMPES AUTOAMORÇANTES AVEC MOTEUR A' ESSENCE "HONDA"

B2KQ-A/ST (2"X2") GX160

CURVE DI PRESTAZIONE

Tolleranze e curve secondo UNI EN ISO 9906 Appendice A
Le caratteristiche di funzionamento in questo catalogo si intendono con acqua pulita (peso specifico = 1000 kg/m³).

PERFORMANCES CURVES

Tolerances and curves according to UNI EN ISO 9906 Attachment A
The operating characteristics of the catalogue are to be understood with clear water (specific weight = 1000 kg/m³).

COURBES DE PERFORMANCES

Tolérance et courbes conformes aux normes UNI EN ISO 9906 Annexe A.
Les caractéristiques de fonctionnement du catalogue sont entendues pour fonctionnement avec eau propre (poids spécifique = 1000 kg/m³).

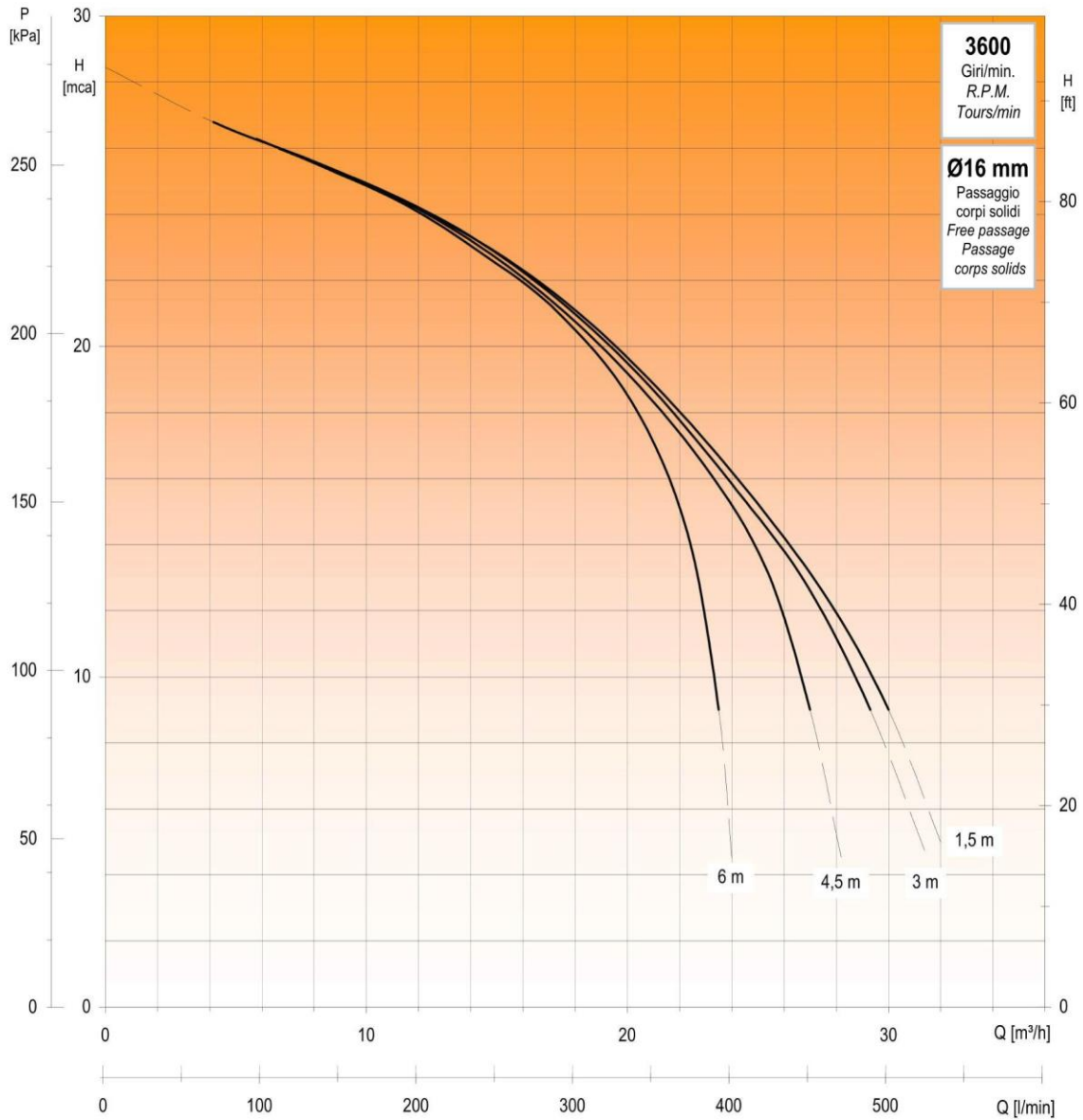

DIMENSIONI

DIMENSIONS

DIMENSIONS

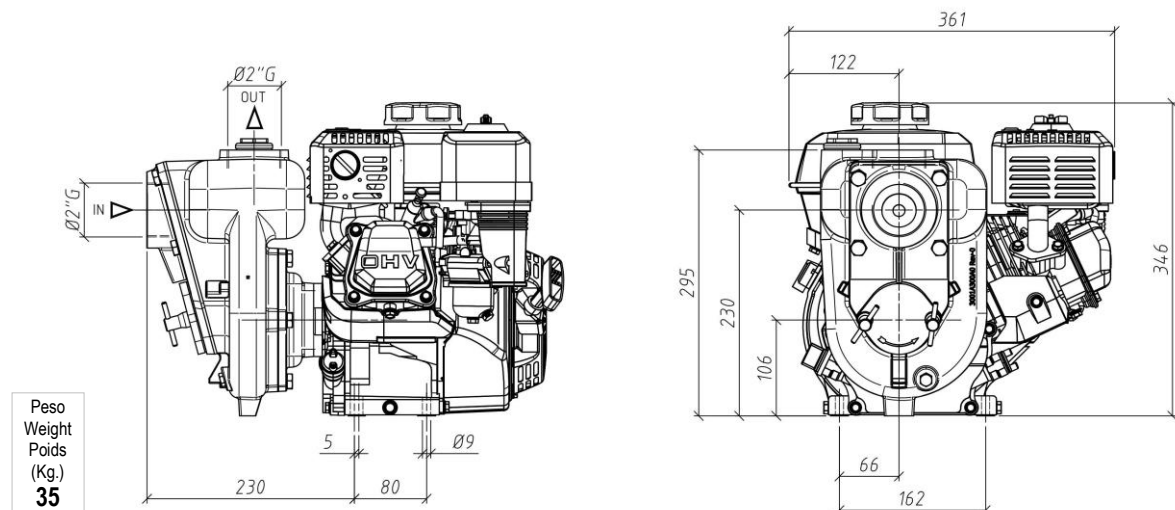

MOTOPOMPE AUTOADESCANTI CON MOTORI BENZINA "HONDA"
SELF PRIMING MOTOR PUMPS WITH "HONDA" GASOLINE ENGINES
MOTOPOMPES AUTOAMORÇANTES AVEC MOTEUR A' ESSENCE "HONDA"



B2KQ-A/ST (2"X2") GX 160

ACCESSORI

ACCESSORIES

ACCESSOIRES



(*R) Base con maniglie Cat.L066
 Base with handles – Base avec poignées



(*R) Gabbia senza porta batteria Cat.L116
 Medium cage – Cage moyenne



(*E) Carrello a 2 ruote con porta batteria Cat.9891
 2-wheels medium trolley – Brouette moyenne avec 2 roues



(*E) Carrello Medio Cat.1220
 Medium trolley – Brouette Moyenne



Tubo aspirazione Ø50 in PVC Cat.9113
 Plasticized PVC hose – Tuyau en PVC plastifié



Tubo mandata Ø50 Cat.9105
 Flat plasticized PVC hose – Tuyau plat en PVC plastifié



Raccordi rapidi dritti PVC / Ottone Cat.1017 Cat.1024
 Straight hose connections – Raccords rapide droits



Raccordi rapidi curvi PVC / Ottone Cat.1083 Cat.1034
 Curved hose connections – Raccords rapides corbe



Succheruole PVC / Ottone Cat.P974 Cat.5457
 Suction strainers – Crépines sans clapet

(*R) : Avviamento a strappo con autoavvolgente – Recoil starting – Démarrage lanceur E: Avviamento Elettrico – Electric starting – Démarrage électrique