

MOTOPOMPE AUTOADESCANTI CON MOTORI DIESEL "KOHLER" SELF PRIMING MOTOR PUMPS WITH "KOHLER" DIESEL ENGINES MOTOPOMPES AUTOAMORÇANTES AVEC MOTEUR DIESEL "KOHLER"

GMP
PUMPS



G21MK-A/B (2"X2") KD15 350 Stage V



IMPIEGHI

Motopompa autoadescante in bronzo realizzata in versione monoblocco a girante multipalare aperta a rasamento, particolarmente adatta per uso marino e circolazione di acqua di mare.
 Corpo, girante e valvola in bronzo, albero in acciaio inox.
 Una valvola a clapet posta all'interno del corpo pompa impedisce lo svuotamento della pompa dopo l'arresto.

USES

Bronze self-priming motor pump monobloc execution with multi-blades open impeller, suitable for pumping sea water.
 Pump casing, impeller and valve are in bronze, the shaft is in stainless steel.
 A suitable non return valve is placed inside the pump body to avoid the empty after stopping.

APPLICATION

Motopompe autoamorçantes monobloc en bronze avec turbine ouverte plusieurs pales, indiquée pour d'eau de mer.
 Corps, turbine et valve sont en bronze, arbre en acier inox.
 Une valve à clapet est placée dans le corps de la pompe pour éviter le vidage après l'arrêt.

CARATTERISTICHE

Altezza massima di aspirazione: 6m.
 Max temperatura del liquido: +70°C
 Max passaggio corpi solidi: 6 mm
 Portata massima: 27,5 m³/h
 Prevalenza massima: 4,2 bar
 Ø aspirazione e mandata: 2" G

FEATURES

Max. suction depth: 6 m.
 Max. liquid temperature: +70°C
 Max. solids diameter: 6 mm
 Max. delivery: 27,5 m³/h
 Max. manometric head: 4,2 bar
 Ø inlet / outlet: 2" G

CARACTERISTIQUES

Hauteur d'aspiration maximale: 6 m.
 Température Max.: +70°C
 Max. diamètre des solides: 6 mm
 Débit maximum: 27,5 m³/h
 Hauteur manométrique: 4,2 bars
 Ø aspiration & refoulement: 2" G

CARATTERISTICHE COSTRUTTIVE

Corpo pompa: Bronzo (ASTM B145 C 95800)
 Corpo valvola: Bronzo (ASTM B145 C 95800)
 Flangia tenuta: Bronzo (ASTM B145 C 95800)
 Supporto motore: Ghisa (EN-GJL-250)
 Girante: Bronzo (ASTM B145 C 95800)
 Albero motore: Acciaio Inox AISI 316
 Tenuta mecc.: Carbone/Allumina/Nbr/Aisi316 (BVP2GG)

CONSTRUCTIVE CHARACTERISTICS

Pump body: Bronze (ASTM B145 C 95800)
 Valve body: Bronze (ASTM B145 C 95800)
 Seal disc: Bronze (ASTM B145 C 95800)
 Support: Cast iron (EN-GJL-250)
 Impeller: Bronze (ASTM B145 C 95800)
 Motor shaft: Stainless Steel AISI316
 Seal: Carbon/Alumina/Nbr/Aisi316 (BVP2GG)

CARACTERISTIQUES DE CONSTRUCTION

Corps de pompe: Bronze (ASTM B145 C 95800)
 Corps valve: Bronze (ASTM B145 C 95800)
 Porte Garniture m.: Bronze (ASTM B145 C 95800)
 Support: Fonte (EN-GJL-250)
 Turbine: Bronze (ASTM B145 C 95800)
 Arbre moteur: Acier inox AISI316
 Garniture: Charbon/Albumine/Nbr/Aisi316 (BVP2GG)

VERSIONI SPECIALI E OPZIONI

Materiali di costruzione:
 (1) Bronzo marino (ASTM B145 C 95800)
 (2) Acciaio Inox AISI 316 (1.4408)
 Tenute meccaniche diverse
 Accessori a richiesta:
 Base con maniglie
 Gabbia
 Carrello
 Raccordi e tubi

SPECIAL VERSIONS

Constructive materials:
 (1) Marine Bronze (ASTM B145 C95800)
 (2) Cast stainless steel AISI 316 (1.4408)
 Different mechanical seals
 Accessories on request:
 Base with handles
 Cage
 Trolley
 Fittings and pipes

VERSIONS SPECIALES

Matériaux constructifs:
 (1) Bronze marin (ASTM B145 C95800)
 (2) Acier inoxydable fondu AISI 316 (1.4408)
 Garnitures mécaniques différentes
 Accessoires sur demande:
 Base avec poignées
 Cage
 Brouette
 Raccords et tuyaux

DATI MOTORE

MOTOR DATA

MOTEUR

Modello Model Modèle	Tipo Type Type	Cilindri Cylinders Cylindrées	Cilindrata Displacement Cylindrée	Potenza - NA Rating - NA Puissance- NA		Capacità serb. Tank capacity Contenance du réservoir	N° Giri Tours/min. R.P.M.	Avviamento Starter Démarrage
		[N°]	[cm³]	[kW]	[CV]	[L]		
KD15 350 E536	Motore diesel 4 tempi raffreddato ad aria 4-Stroke air cooled diesel engine Moteur diesel 4 temps, refroidi par air	1	349	5	6,8	4,3	3600	R / E

R : Avviamento a strappo con autoavvolgente - Recoil starting - Démarrage lanceur

E: Avviamento Elettrico - Electric starting - Démarrage électrique

CURVE DI PRESTAZIONE

Tolleranze e curve secondo UNI EN ISO 9906 Appendice A
Le caratteristiche di funzionamento in questo catalogo si intendono con acqua pulita (peso specifico = 1000 kg/m³).

PERFORMANCES CURVES

Tolerances and curves according to UNI EN ISO 9906 Attachment A
The operating characteristics of the catalogue are to be understood with clear water (specific weight = 1000 kg/m³).

COURBES DE PERFORMANCES

Tolérance et courbes conformes aux normes UNI EN ISO 9906 Annexe A.
Les caractéristiques de fonctionnement du catalogue sont entendues pour fonctionnement avec eau propre (poids spécifique = 1000 kg/m³).

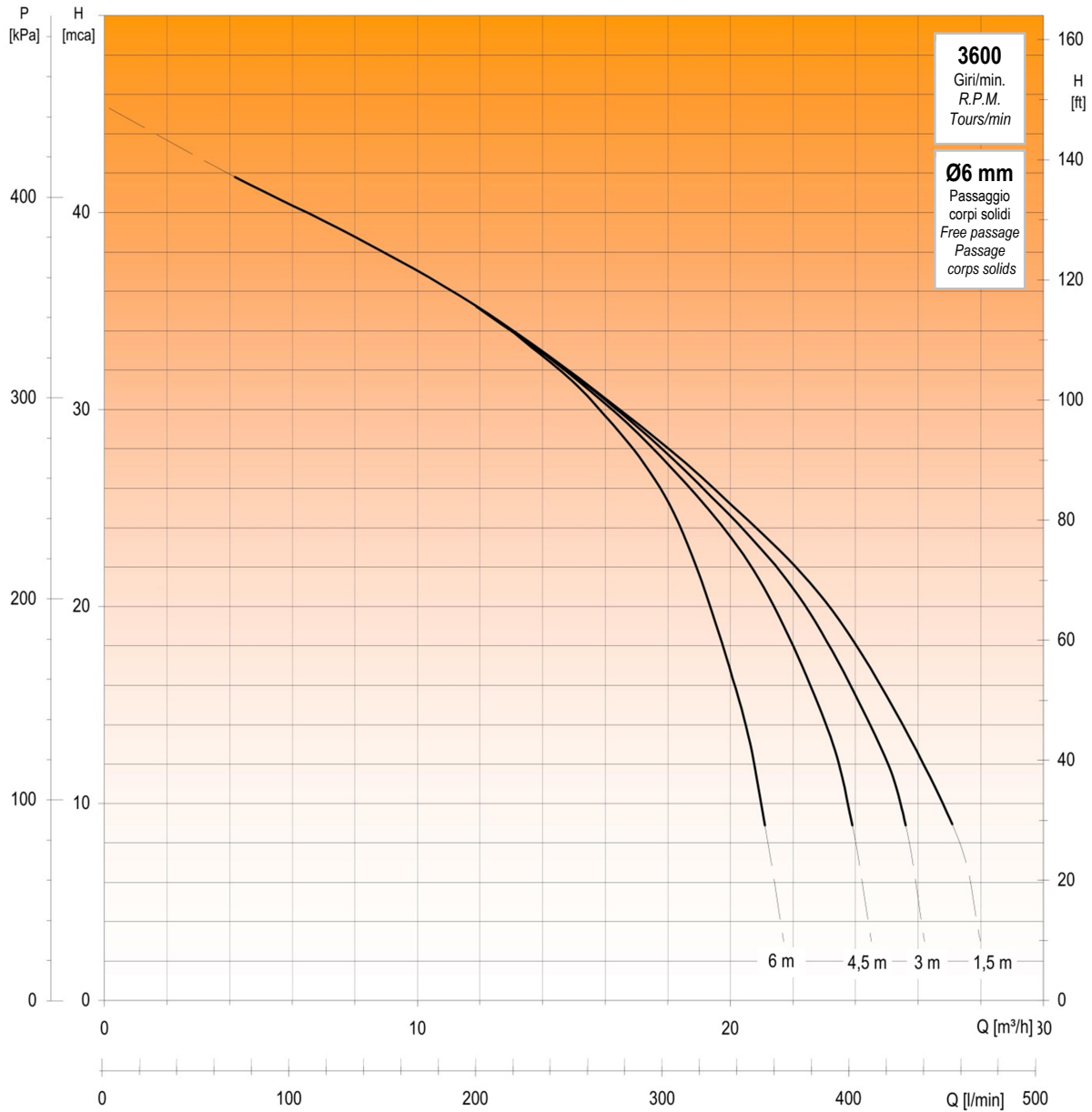

DIMENSIONI

DIMENSIONS

DIMENSIONS

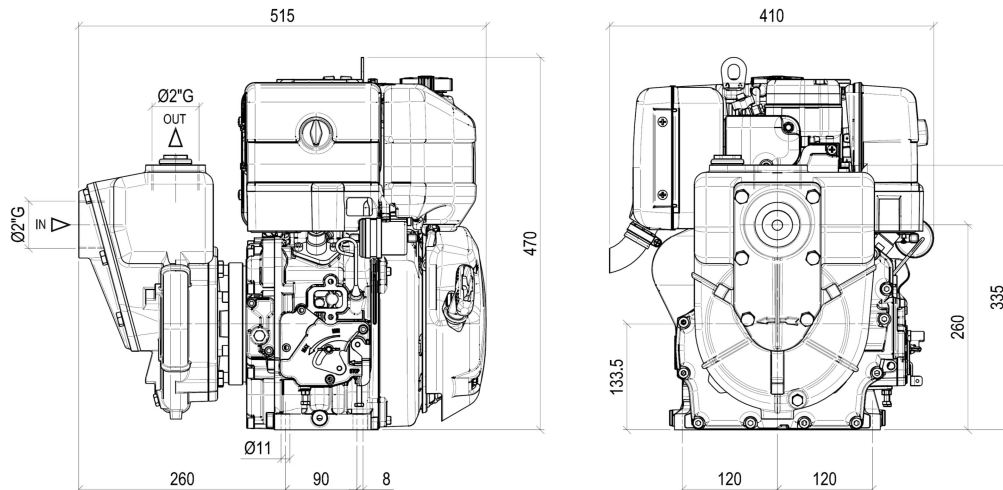

Peso
Weight
Poids
(Kg.)
57,5

La GMP si riserva la facoltà di modificare senza preavviso i dati riportati in questo catalogo - GMP can alter without notifications the data mentioned in this catalogue - GMP se réserve le droit de modifier sans préavis les données techniques dans ce catalogue.

G.M.P. S.p.A. - Via Sale, 119/121 - 25064 Gussago (BS) Italy - Vendite Italia 030.2775 420 - Export +39 030 2775 412 _ 414

www.gmppumps.com - info@gmppumps.com

MOTOPOMPE AUTOADESCANTI CON MOTORI DIESEL "KOHLER"
SELF PRIMING MOTOR PUMPS WITH "KOHLER" DIESEL ENGINES
MOTOPOMPES AUTOAMORÇANTES AVEC MOTEUR DIESEL "KOHLER"

GMP
PUMPS

G2TMK-A/B (2"X2") KD15 350 Stage V

ACCESSORI

ACCESSORIES

ACCESSOIRES



(*R)
 Gabbia senza porta batteria Cat.L116
 Medium cage – Cage moyenne

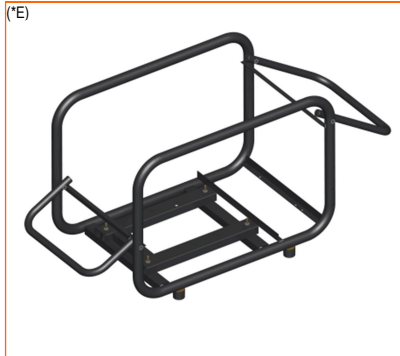

(*E)
 Gabbia senza con porta batteria Cat.F934
 Medium cage – Cage moyenne



(*R)
 Carrello medio Cat.1220
 Medium trolley – Brouette moyenne



(*R)
 Carrello a 2 ruote senza porta batteria Cat.L090
 2-wheels medium trolley – Brouette moyenne avec 2 roues



(*E)
 Carrello a 2 ruote con porta batteria Cat.9891
 2-wheels medium trolley – Brouette moyenne avec 2 roues



(*E)
 Carrello super Cat.1707
 Super trolley – Brouette super



Tubo aspirazione Ø50 in PVC Cat.9113
 Plasticized PVC hose – Tuyau en PVC plastifié



Tubo mandata Ø50 Cat.9105
 Flat plasticized PVC hose – Tuyau plat en PVC plastifié



Raccordi rapidi diritti PVC / Ottone Cat.1017
 Straight hose connections – Raccords rapide droits



Raccordi rapidi curvi PVC / Ottone Cat.1083
 Curved hose connections – Raccords rapides corbe



Succheruole PVC / Ottone Cat.P974
 Suction strainers – Crépines sans clapet

(*R) : Avviamento a strappo con autoavvolgente – Recoil starting – Démarrage lanceur E: Avviamento Elettrico – Electric starting – Démarrage électrique



MOTOPOMPE AUTOADESCANTI CON MOTORI DIESEL "KOHLER"
SELF PRIMING MOTOR PUMPS WITH "KOHLER" DIESEL ENGINES
MOTOPOMPES AUTOAMORÇANTES AVEC MOTEUR DIESEL "KOHLER"

G2TMK-A/B (2" X 2") KD15 350 Stage V

G.M.P. spa

25064 Gussago (BS) Italy - Via Sale 119/121
<http://www.gmppumps.com>
E-mail: info@gmppumps.com

Vendita Italia

Tel.: 0302775420
E-mail: ucm@gmppumps.com
Ricambi
Tel.: 0302775430
E-mail: comm@gmppumps.com

Export

Tel.: 0302775412 - 414
E-mail: export@gmppumps.com - export1@gmppumps.com

  
M A D E I N I T A L Y