

MOTOPOMPE AUTOADESCANTI CON MOTORI BENZINA

SELF PRIMING MOTOR PUMPS WITH GASOLINE ENGINES

MOTOPOMPES AUTOAMORÇANTES AVEC MOTEUR ESSENCE

GMP
PUMPS



B3XR-A (3"X3") MX400

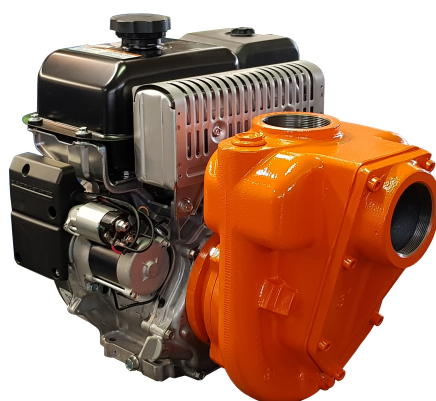

IMPIEGHI

Motopompa autoadescante realizzata in versione monoblocco a girante multipalare aperta adatta per travaso di acque chiare o leggermente sporche, assolutamente non abrasive.
Una valvola a clapet posta all'interno del corpo pompa impedisce lo svuotamento della pompa dopo l'arresto.

USES

Self priming motor pump monobloc execution with multi-blades open impeller, suitable for pumping clean or slightly dirty waters, absolutely not abrasive.
A suitable non return valve is placed inside the pump body to avoid the empty of the pump after stopping.

APPLICATION

Motopompe autoamorçantes monobloc avec turbine ouverte plusieurs pales, indiquée pour le transvasement d'eau claire ou légèrement chargées, mai absolument pas abrasive.
Une valve à clapet est placée dans le corps de la pompe pour éviter le vidage après l'arrêt.

CARATTERISTICHE

Altezza massima di aspirazione: 6m.
Max temperatura del liquido: +70°C
Max passaggio corpi solidi: 19 mm
Portata massima: 88 m³/h
Prevalenza massima: 4,2 bar
Ø aspirazione e mandata: 3"G

FEATURES

Max. suction depth: 6 m.
Max. liquid temperature: +70°C
Max. solids diameter: 19 mm
Max. delivery: 88 m³/h
Max. manometric head: 4,2 bar
Ø inlet / outlet: 3"G

CARACTERISTIQUES

Hauteur d'aspiration maximale: 6 m.
Température Max.: +70°C
Max. diamètre des solides: 19 mm
Débit maximum: 88 m³/h
Hauteur manométrique: 4,2 bars
Ø aspiration & refoulement: 3"G

CARATTERISTICHE COSTRUTTIVE

Corpo pompa: Ghisa (EN-GJL-200)
Corpo valvola: Ghisa (EN-GJL-200)
Supporto motore: Ghisa (EN-GJL-250)
Girante: Ghisa (EN-GJL-200)
Bussola albero: Acciaio inox AISI 316
Tenuta mecc.: Carbone/Allumina/Nbr (BVP2FF1)

CONSTRUCTIVE CHARACTERISTICS

Pump body: Cast iron (EN-GJL-200)
Valve body: Cast iron (EN-GJL-200)
Support: Cast iron (EN-GJL-250)
Impeller: Cast iron (EN-GJL-200)
Sleeve: Stainless steel AISI316
Seal: Carbon/Alumina/Nbr (BVP2FF1)

CARACTERISTIQUES DE CONSTRUCTION

Corps de pompe : Fonte (EN-GJL-200)
Corps valve: Fonte (EN-GJL-200)
Support: Fonte (EN-GJL-250)
Turbine: Fonte (EN-GJL-200)
Manchon: Acier Inox AISI 316
Garniture: Charbon/Alumine/Nbr (BVP2FF1)

VERSIONI SPECIALI E OPZIONI

Materiali di costruzione:
1- Bronzo marino (ASTM B145 C 95800)
2- Acciaio Inox AISI 316 (1.4408)
Tenute meccaniche diverse
Accessori a richiesta:
Gabbia
Carrello
Raccordi e tubi

SPECIAL VERSIONS

Constructive materials:
1- Marine Bronze (ASTM B145 C95800)
2- Cast stainless steel AISI 316 (1.4408)
Different mechanical seals
Accessories on request:
Cage
Trolley
Fittings and pipes

VERSIONS SPECIALES

Matériaux constructifs:
1- Bronze marin (ASTM B145 C95800)
2- Acier inoxydable fondu AISI 316 (1.4408)
Garnitures mécaniques différentes
Accessoires sur demande :
Cage
Brouette
Raccords et tuyaux

DATI MOTORE

MOTOR DATA

MOTEUR

Modello Model Modèle	Tipo Type Type	Cilindri Cylinders Cylindrées	Cilindrata Displacement Cylindrée	Potenza – NA Rating – NA Puissance- NA		Capacità serb. Tank capacity Contenance du réservoir	N° Giri Tours/min. R.P.M.	Avviamento Starter Démarrage
		[N°]	[cm³]	[kW]	[CV]	[L]		
MX400	Motore Benzina 4 tempi raffreddato ad aria 4-Stroke air cooled gasoline engine Moteur Essence 4 temps, refroidi par air	1	402	7,8	10,4	6,1	3600	R / E

R : Avviamento a strappo con autoavvolgente – Recoil starting – Démarrage lanceur E: Avviamento Elettrico – Electric starting – Démarrage électrique

La GMP si riserva la facoltà di modificare senza preavviso i dati riportati in questo catalogo – GMP can alter without notifications the data mentioned in this catalogue. – GMP se réserve le droit de modifier sans préavis les données techniques dans ce catalogue.

G.M.P. S.p.A. – Via Sale, 119/121 – 25064 Gussago (BS) Italy – Vendite Italia 030.2775 420 – Export +39 030 2775 412 _ 414

www.gmppumps.com – info@gmppumps.com

MOTOPOMPE AUTOADESCANTI CON MOTORI BENZINA

SELF PRIMING MOTOR PUMPS WITH GASOLINE ENGINES

MOTOPOMPES AUTOAMORÇANTES AVEC MOTEUR ESSENCE

B3XR-A (3"X3") MX400

CURVE DI PRESTAZIONE

Tolleranze e curve secondo UNI EN ISO 9906 Appendice A
Le caratteristiche di funzionamento in questo catalogo si intendono con acqua pulita (peso specifico = 1000 kg/m³).

PERFORMANCES CURVES

Tolerances and curves according to UNI EN ISO 9906 Attachment A
The operating characteristics of the catalogue are to be understood with clear water (specific weight = 1000 kg/m³).

COURBES DE PERFORMANCES

Tolérance et courbes conformes aux normes UNI EN ISO 9906 Annexe A.
Les caractéristiques de fonctionnement du catalogue sont entendues pour fonctionnement avec eau propre (poids spécifique = 1000 kg/m³).

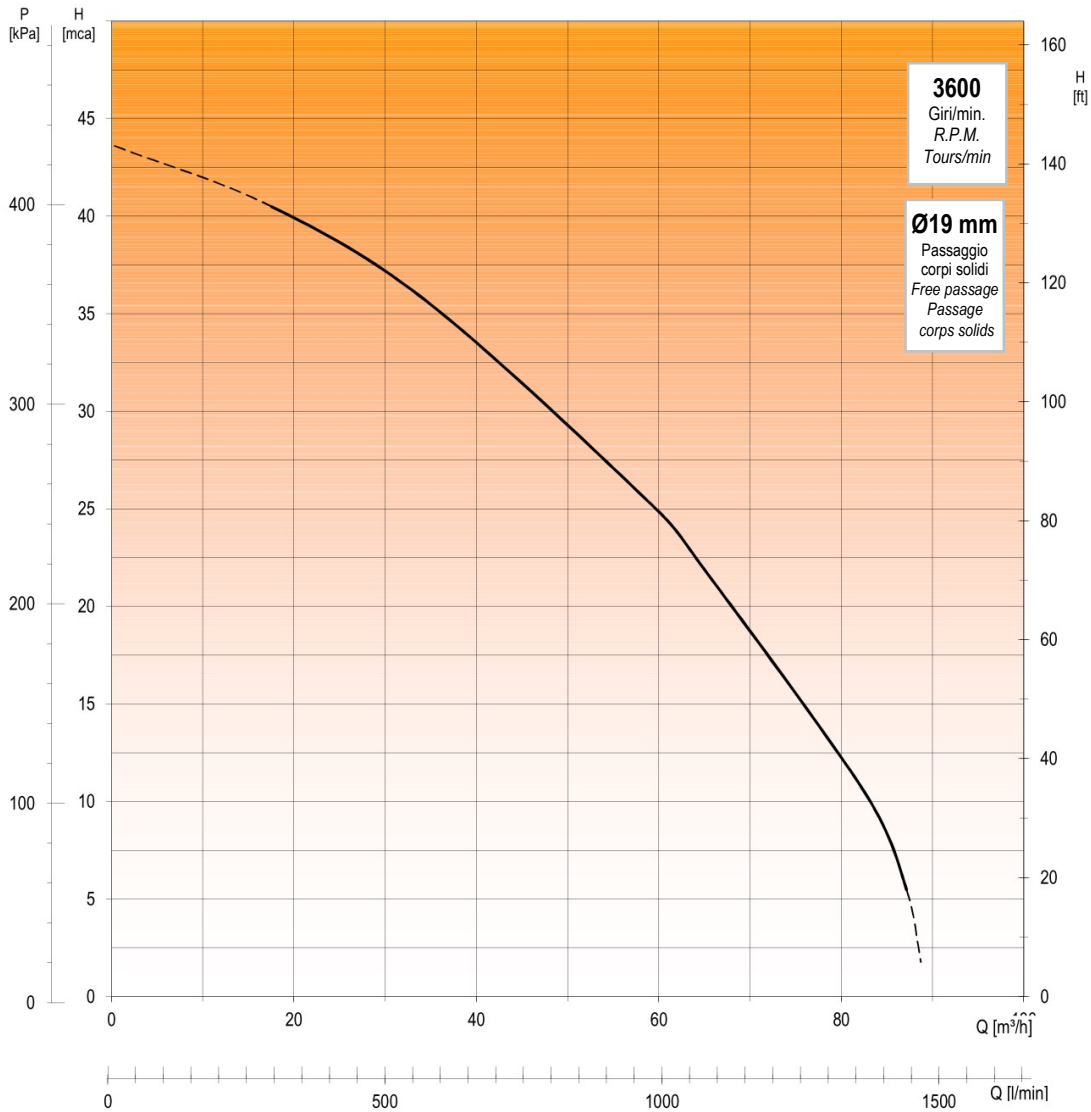

DIMENSIONI

DIMENSIONS

DIMENSIONS

Peso
Weight
Poids
(Kg.)
74

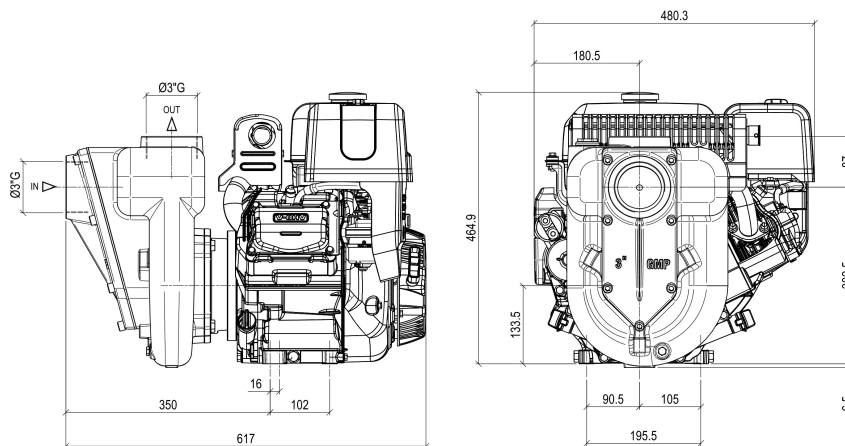

MOTOPOMPE AUTOADESCANTI CON MOTORI BENZINA
SELF PRIMING MOTOR PUMPS WITH GASOLINE ENGINES
MOTOPOMPES AUTOAMORÇANTES AVEC MOTEUR ESSENCE

GMP
PUMPS

B3XR-A (3"X3") MX400

ACCESSORI

ACCESSORIES

ACCESSOIRES



Carrello Grande
Big Trolley - Brouette grande

Cat.1708



Carrello Super
Super Trolley - Brouette Super

Cat.1707



Gabbia Grande
Big Cage - Cage Grande

Cat.F916



Carrello Grande 2 ruote e manico
2-wheels big trolley with handle - Brouette Grande ave 2 roues et poignées

Cat.F917



Raccordi rapidi dritti in Acciaio Zincato
Straight hose connections - Raccords rapide droits

Cat.1027



Raccordi rapidi curvi in Acciaio Zincato
Curved hose connections - Raccords rapides corbe

Cat.1037



Succheruole in Acciaio Zincato
Suction strainers - Crépines sans clapet

Cat.1051



Tubo aspirazione Ø80 in PVC
Plasticized PVC hose - Tuyau en PVC plastifié

Cat.9114



Tubo mandata Ø80
Flat plasticized PVC hose - Tuyau plat en PVC plastifié

Cat.9107

MOTOPOMPE AUTOADESCANTI CON MOTORI BENZINA
SELF PRIMING MOTOR PUMPS WITH GASOLINE ENGINES
MOTOPOMPES AUTOAMORÇANTES AVEC MOTEUR ESSENCE

GMP
PUMPS

B3XR-A (3"X3") MX400

G.M.P. spa

25064 Gussago (BS) Italy - Via Sale 119/121
<http://www.gmppumps.com>
E-mail: info@gmppumps.com

Vendita Italia

Tel.: 0302775420
E-mail: ucm@gmppumps.com
Ricambi

Tel.: 0302775430
E-mail: comm@gmppumps.com

Export

Tel.: 0302775412 - 414
E-mail: export@gmppumps.com - export1@gmppumps.com

  
M A D E I N I T A L Y

La GMP si riserva la facoltà di modificare senza preavviso i dati riportati in questo catalogo - GMP can alter without notifications the data mentioned in this catalogue. - GMP se réserve le droit de modifier sans préavis les données techniques dans ce catalogue.

G.M.P. S.p.A. - Via Sale, 119/121 - 25064 Gussago (BS) Italy - Vendite Italia 030.2775 420 - Export +39 030 2775 412 _ 414
www.gmppumps.com - info@gmppumps.com