

ELETTROPOMPE AUTOADESCANTI PER GASOLIO

SELF PRIMING ELECTRIC PUMPS FOR DIESEL FUEL

ELECTROPOMPES AUTOAMORÇANTES POUR DIESEL

GMP
PUMPS

B3XR-A 4KW



DESCRIZIONE

Elettropompa autoadescante in ghisa adatta per travaso gasolio, realizzata in versione monoblocco a girante multipalare aperta.

Una valvola a clapet, con guarnizione in Viton, posta all'interno del corpo pompa impedisce lo svuotamento della pompa dopo l'arresto.

DESCRIPTION

Cast iron self priming electric pump suitable for diesel fuel transfer, made in monobloc execution with multi-blades open impeller.

A non return valve, with Viton gasket, is placed inside the pump body to avoid the empty after stopping.

DESCRIPTION

Electropompe autoamorçantes en fonte adaptée au transfert de carburante diesel, réalisée en version monobloc avec turbine ouverte plusieurs pales.

Une valve à clapet, avec garniture en Viton, est placée dans le corps de la pompe pour éviter le vidage après l'arrêt.

CARATTERISTICHE

Altezza massima di aspirazione:	6 m.
Max temperatura del liquido:	+20°C
Max passaggio corpi solidi:	19 mm
Portata massima:	78 m³/h
Prevalenza massima:	2,6 bar
Ø aspirazione:	3"G
Ø mandata:	3"G

FEATURES

Max. suction depth:	6 m.
Max. liquid temperature:	+20°C
Max. solids diameter:	19 mm
Max. delivery:	78 m³/h
Max. manometric head:	2,6 bar
Ø inlet:	3"G
Ø outlet:	3"G

CARACTERISTIQUES

Hauteur d'aspiration maximale:	6 m.
Température Max.:	+20°C
Max. diamètre des solides:	19 mm
Débit maximum:	78 m³/h
Hauteur manométrique:	2,6 bars
Ø aspiration:	3"G
Ø refoulement:	3"G

MATERIALI (Esecuzione Standard)

Corpo pompa:	Ghisa
Corpo valvola:	Ghisa
Girante:	Ghisa
Supporto motore:	Ghisa
Albero motore:	Acciaio inox Aisi 316 (1.4401)
Tenuta mecc.:	Viton/Carbone/Allumina

MATERIALS (Standard Execution)

Pump body:	Cast iron
Valve body:	Cast iron
Impeller:	Cast iron
Support:	Cast iron
Motor shaft:	Stainless steel Aisi 316 (1.4401)
Seal:	Viton/Carbon/Alumina

MATERIAUX (Exécution Standard)

Corps de pompe:	Fonte
Corps valve:	Fonte
Turbine:	Fonte
Support:	Fonte
Arbre moteur:	Acier Inox Aisi 316 (1.4401)
Garniture:	Viton/Charbon/Alumine

VERSIONI SPECIALI

Tenute meccaniche e altre parti in materiali diversi
Tensioni speciali
Frequenza 60Hz

SPECIAL VERSION

Mechanical seals and other parts in different materials.
Special voltages - Frequency 60Hz

VERSIONS SPECIALES

Garnitures mécaniques et autres pièces en différents matériaux.
Voltages spéciaux - Fréquence 60Hz

DATI TECNICI

TECHNICAL DATA

DONNES TECHNIQUES

Tipo Type	P2 (kW)	V (Volt)	Freq. (Hz)	Corrente nominale Rated current Intensité (A)	Protez. Protection	Giri/min RPM Tours/min	Cond. (µF)	Peso Weight Poids (Kg.)	A/B/C (mm)
B3XR-A	4	400/690	50	7,88 / 4,55	IP 55	2900	-	74	410x770x645

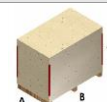

ELETTROPOMPE AUTOADESCANTI PER GASOLIO

SELF PRIMING ELECTRIC PUMPS FOR DIESEL FUEL

ELECTROPOMPES AUTOAMORÇANTES POUR DIESEL

B3XR-A 4kW

CURVE DI PRESTAZIONE

Tolleranze e curve secondo UNI EN ISO 9906
Appendice A

PERFORMANCES CURVES

Tolerances and curves according to UNI EN ISO 9906
Attachment A

COURBES DE PERFORMANCES

Tolérance et courbes conformes aux normes UNI EN ISO 9906
Annexe A

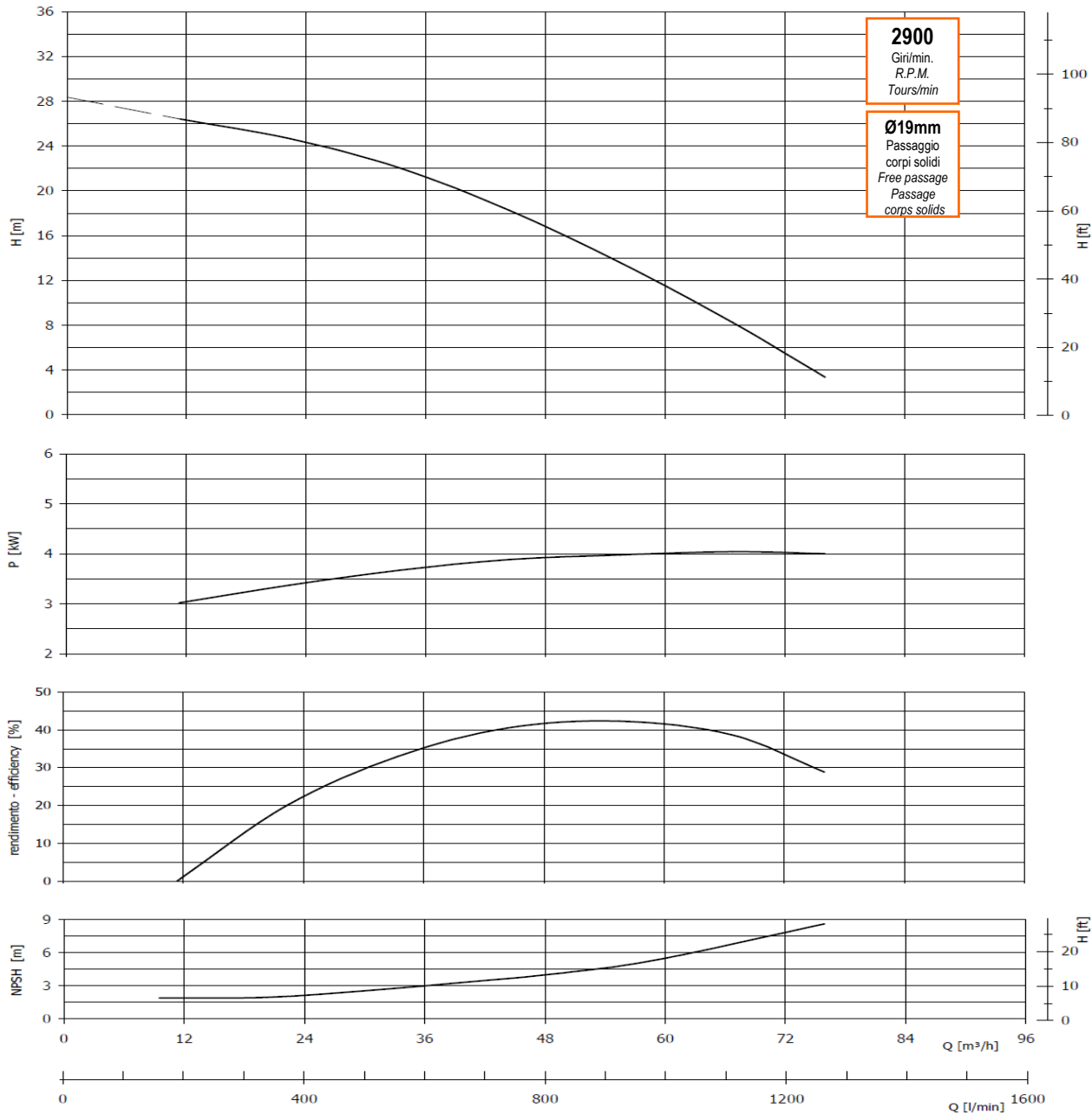

DIMENSIONI

DIMENSIONS

DIMENSIONS

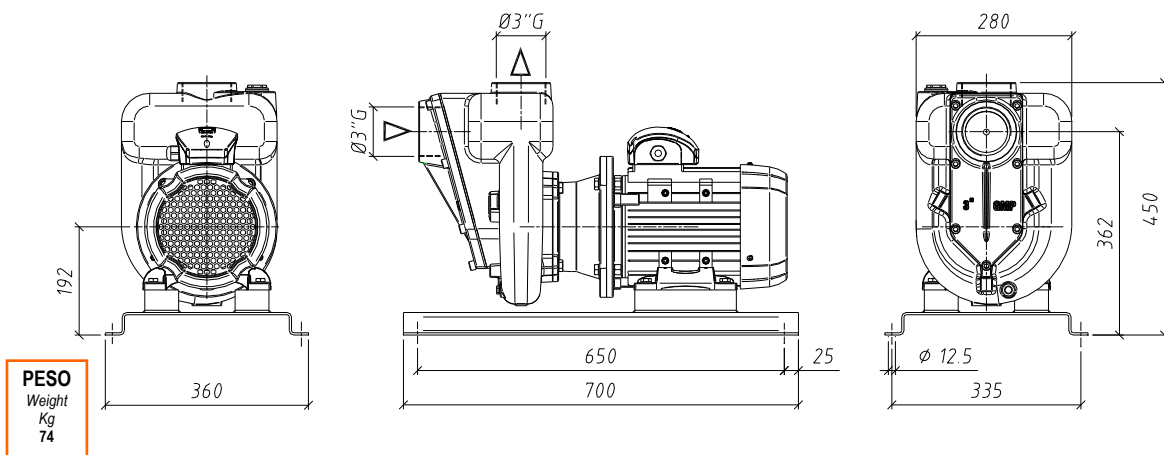

PESO
Weight
Kg
74