

ELETTROPOMPE AUTOADESCANTI PER GASOLIO

SELF PRIMING ELECTRIC PUMPS FOR DIESEL FUEL

ELECTROPOMPES AUTOAMORÇANTES POUR DIESEL



B1KQ-A 0,55KW



DESCRIZIONE

Elettropompa autoadescante in ghisa adatta per travaso gasolio, realizzata in versione monoblocco a girante multipalare aperta a rasamento. Una valvola a clapet, con guarnizione in Viton, posta all'interno del corpo pompa impedisce lo svuotamento della pompa dopo l'arresto.

DESCRIPTION

Cast iron self priming electric pump suitable for diesel fuel transfer, made in monobloc execution with multi-blades open impeller. A non return valve, with Viton gasket, is placed inside the pump body to avoid the empty after stopping

DESCRIPTION

Electropompe autoamorçantes en fonte adapté pour le transfert de carburante diesel, réalisée en version monobloc avec turbine ouverte plusieurs pales. Une valve à clapet, avec garniture en Viton, est placée dans le corps de la pompe pour éviter le vidage après l'arrêt.

CARATTERISTICHE

Altezza massima di aspirazione: 6 m.
Max temperatura del liquido: +20°C
Max passaggio corpi solidi: 6 mm
Portata massima: 8 m³/h
Prevalenza massima: 1,2 bar
Ø aspirazione e mandata: 1" G

FEATURES

Max. suction depth: 6 m.
Max. liquid temperature: +20°C
Max. solids diameter: 6 mm
Max. delivery: 8 m³/h
Max. manometric head: 1,2 bar
Ø inlet / outlet: 1" G

CARACTERISTIQUES

Hauteur d'aspiration maximale: 6 m.
Température Max.: +20°C
Max. diamètre des solides: 6 mm
Débit maximum: 8 m³/h
Hauteur manométrique: 1,2 bars
Ø aspiration & refoulement: 1" G

VERSIONE

Corpo pompa: Ghisa
Corpo valvola: Ghisa
Girante: Ghisa
Supporto motore: Alluminio
Albero motore: Acciaio inox Aisi 316 (1.4401)
Tenuta meccanica: Viton/Carbone/Allumina

VERSION

Pump body: Cast iron
Valve body: Cast iron
Impeller: Cast iron
Motore support: Aluminium
Motor shaft: Stainless steel Aisi 316 (1.4401)
Mechanical seal: Viton/carbon/Allumina

EXECUTION

Corps de pompe: Fonte
Corps valve: Fonte
Turbine: Fonte
Support moteur: Aluminium
Arbre moteur: Acier Inox Aisi 316 (1.4401)
Garniture mécanique: Viton/Charbon/Alumine

VERSIONI SPECIALI

Tenute meccaniche materiali diversi
Tensioni speciali
Frequenza 60Hz

SPECIAL VERSION

Different mechanical seals
Special voltages
Frequency 60Hz

VERSIONS SPECIALES

Garnitures mécaniques différentes
Voltages spéciaux
Fréquence 60Hz

DATI TECNICI

TECHNICAL DATA

DONNES TECHNIQUES

Tipo Type	P2 (kW)	V (Volt)	Freq. (Hz)	Corrente nominale Rated current Intensité (A)	Protez. Protection	Giri/min RPM Tours/min	Cond. (µF)	Peso Weight Poids (Kg.)	A/B/C (mm)
B1KQ-A M. (*)	0,55	230	50	4,10	IP 54	2800	12,5	15	200x430x360
B1KQ-A T. (**)		230/400		3 / 1,8			-		





ELETTROPOMPE AUTOADESCANTI PER GASOLIO

SELF PRIMING ELECTRIC PUMPS FOR DIESEL FUEL

ELECTROPOMPES AUTOAMORÇANTES POUR DIESEL

B1KQ-A 0,55kW

CURVE DI PRESTAZIONE

Tolleranze e curve secondo UNI EN ISO 9906
Appendice A

PERFORMANCES CURVES

Tolerances and curves according to UNI EN ISO 9906
Attachment A

COURBES DE PERFORMANCES

Tolérance et courbes conformes aux normes UNI EN ISO 9906
Annexe A

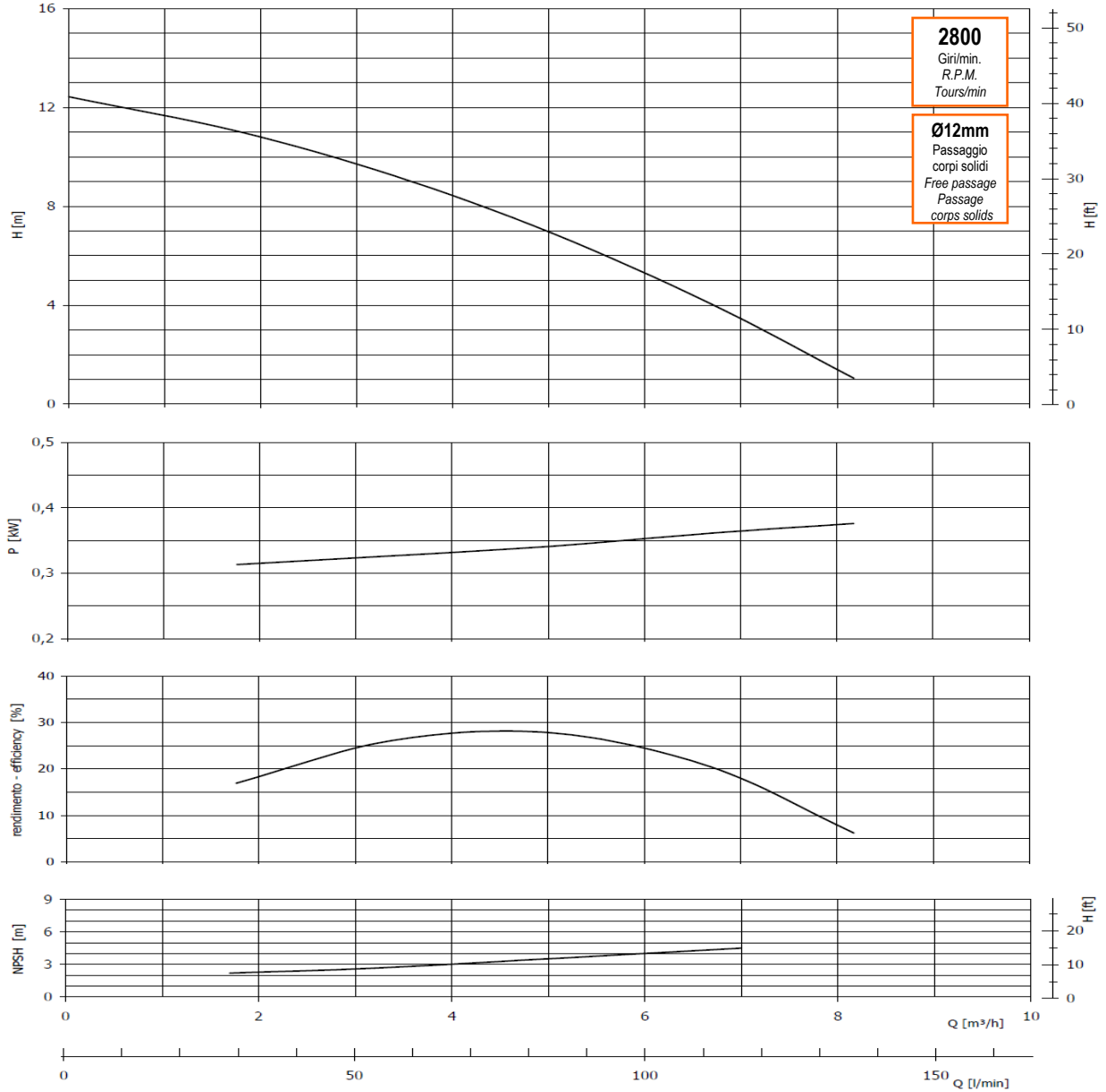

DIMENSIONI

DIMENSIONS

DIMENSIONS

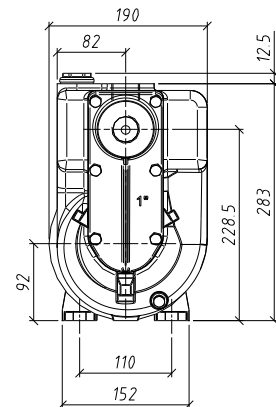
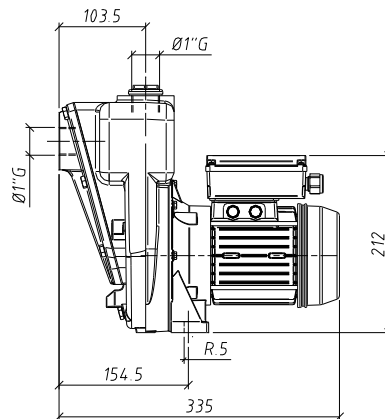
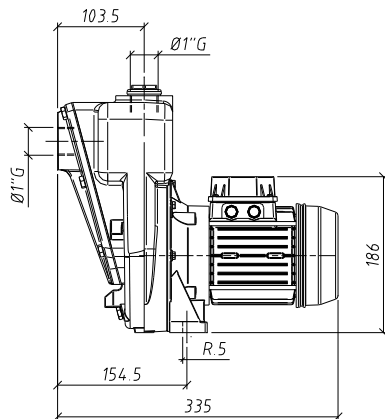

(**)

(*)

La GMP si riserva la facoltà di modificare senza preavviso i dati riportati in questo catalogo - GMP can alter without notifications the data mentioned in this catalogue. - GMP se réserve le droit de modifier sans préavis les données techniques dans ce catalogue.

G.M.P. S.p.A. - Via Sale, 119/121 - 25064 Gussago (BS) Italy - Vendite Italia 030.2775 420 _ 421 - Export +39 030 2775 412 _ 414

www.gmppumps.com - info@gmppumps.com